

CITY OF
TOPEKA

A G E N D A

TOPEKA PLANNING COMMISSION

**MONDAY, FEBRUARY 19, 2024
6:00 P.M.**

**214 EAST 8TH STREET
CITY COUNCIL CHAMBERS, 2ND FLOOR
MUNICIPAL BUILDING
TOPEKA, KANSAS 66603**

MEETINGS ARE LIVESTREAMED AT WWW.TOPEKASPEAKS.ORG

Persons addressing the Planning Commission will be limited to four minutes of public address on a particular agenda item. Debate, questions/answer dialogue or discussion between Planning Commission members will not be counted towards the four-minute time limitation. The Commission by affirmative vote of at least five members may extend the limitation an additional two minutes. The time limitation does not apply to the applicant's initial presentation.

Items on this agenda will be forwarded to the City Council for final consideration.

All information forwarded to the City Council can be accessed via the internet on Thursday prior to the City Council meeting at: <https://www.topeka.org/calendar>



ADA Notice: For special accommodations for this event, please contact the Planning Division at 785-368-3728 at least three working days in advance.

PUBLIC HEARING PROCEDURES

Public Hearings will occur in the following manner:

1. The Topeka Planning Staff will introduce each agenda item and present the staff report and recommendation. Commission members will then have an opportunity to ask questions of staff.
2. If the public hearing involves a rezoning or conditional use permit application, the Chairperson will call for a presentation by the applicant followed by questions from the Commission.
3. Chairperson will then open the public hearing. Each speaker must come to the podium and state his/her name. The time limit is 4 minutes. At the end of each speaker's comments, the Commission will have the opportunity to ask questions.
4. The applicant will be given an opportunity to respond to the public comments.
5. Chairperson will close the public hearing at which time no further public comments will be received. Planning Commission members may inquire of the applicant or staff.
6. Chairperson will then call for a motion on the item. Upon a second to the motion, the Chairperson will call for a roll call vote. Commission members will vote yes, no, or abstain.

Your cooperation and attention to the above noted hearing procedure will ensure an orderly meeting and afford an opportunity for all to participate. Please Be Respectful! Each person's testimony is important regardless of his or her position. **All questions and comments shall be directed to the Chairperson from the podium and not to the applicant, staff or audience.**

Members of the Topeka Planning Commission

Corey Dehn, 2023 Chairperson
Willie Brooks
Jennifer Hannon
Del-Metrius Herron
Jim Kaup
William Naeger
Katy Nelson
Donna Rae Pearson
Jim Tobaben

Topeka Planning Staff

Rhiannon Friedman, Director, Planning & Development Dept.
Dan Warner, AICP, Director, Planning Division
Carlton Scroggins, AICP, Transportation Planning Manager
Mike Hall, AICP, Land Use Planning Manager
Annie Driver, AICP, Planner
Taylor Ricketts, Planner
Bryson Risley, Planner
William Sharp, Planner
Paul Turner, Intern Planner
Megan Rodecap, Zoning Inspector
Amanda Tituana-Feijoo, Administrative Officer
Quinn Cole, Management Analyst

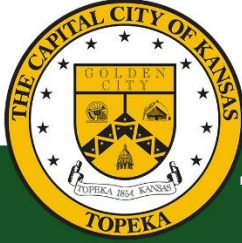

CITY OF
TOPEKA

TOPEKA PLANNING COMMISSION

Agenda for Monday, February 19, 2024

A. Roll call

B. Approval of Minutes – December 18, 2023

C. Election of 2024 Chair and Vice Chair

**D. Declaration of Conflict of Interest/Ex Parte Communications
by members of the commission**

E. Action Items

- 1. PUD12/03A –by EVC Cedar Crest LC** to amend the Planned Unit Development (PUD) Master Plan by changing the land use group from Office and Institutional (O&I2) to Commercial (C-4) to allow retail sales of motorcycles and related merchandise. ***PUD12/03A has been WITHDRAWN by the applicant and thus will not be considered by the Planning Commission.***
- 2. CU23/16- by City of Topeka Utilities Department** requesting a Conditional Use Permit to re-locate and re-build the public utility facility (sanitary sewer pump station) on property zoned “R-1” Single Family Dwelling District and located at 3500 NE Seward Avenue as part of Billard Airport operated by the Metropolitan Topeka Airport Authority (MTAA).
- 3. P23/16- Southland Subdivision #3** A two lot and two tract subdivision on 4.73 acres for duplex development located at the northeast corner of SE Colfax Place and SE 38th Street. This plat provides right-of-way dedication previously shown as a tract on the existing Southland Subdivision No. 2.
- 4. CU24/1-by Don Phillippi & Candi Bryant** requesting a Conditional Use Permit (CUP) on approximately 0.11 acre located at 116 SW The Drive, presently zoned “R-2” Single Family Dwelling District. The CUP will allow for a non-owner-occupied Type II Short-Term Rental (STR) at this location. A CUP is required because the property is within 500 feet of another Type II STR in the neighborhood with a certificate to operate.

F. Public Comment

G. Communications to the Commission

H. Adjournment

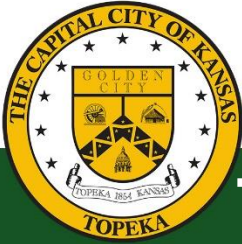

CITY OF
TOPEKA

MINUTES

TOPEKA PLANNING COMMISSION

Monday, December 18, 2023

6:00PM

Members present: Corey Dehn (2023 Chair), Willie Brooks, Jennifer Hannon, Del- Metrius Herron, Jim Kaup, William Naeger, Katy Nelson, Donna Rae Pearson, Jim Tobaben (9)

Members Absent: NA

Staff Present: Rhiannon Friedman, Planning & Development Director, Dan Warner, Planning Director; Mike Hall, Land Use Planning Manager; Annie Driver, Planner; William Sharp, Planner; Bryson Risley, Planner; Amanda Tituana-Feijoo, Administrative Officer; Mary Feighny, Legal

Roll Call – Chairman Corey Dehn called the meeting to order with 9 members present for a quorum.

Approval of Minutes from November 20, 2023

Motion by Commissioner Kaup to approve; **second** by Commissioner Pearson. **APPROVED 9-0.**

Declaration of conflict of interest/ex parte communications – NA

Public Hearing of Z23/11 Helen M Meier Trust, rezoning to combine the parcel with two parcels, directly north along Highway 24 frontage road, which combined will equate to approximately 30 acres for a future speculative light industrial development.

Staff:

Annie Driver presented the staff report and staff's recommendation of approval.

Questions/Comments from Commissioners:

Commissioner Kaup asked if there was a driveway off Vail Avenue. Ms. Driver stated that there is not a driveway currently, and that the only current access is from the property to the south. Ms. Driver also stated that this would have to change as 'you are not permitted to take access to a more intensive zoning district from a less more restrictive zoning district'.

Owner's Representative:

Kevin Holland, Cook, Flatt, and Strobel Engineers

As farmland gets divided among children, remnants get held there. We hoped the strip of land fronting on Vail was at least 20 foot so that we could fire truck access back there. We aren't saying it won't ever get expanded, but that would be for a future time. The contractor has a contract on the property, but the layout required them to push a little more south.

Commissioner Dehn declared the **public hearing open**.

Bridget Meier, 735 NW Vale Ave, the previous meeting was a zoom meeting and we were out -of- town that day. We do not want this rezoned, there is industrial around it, but it is my back yard. When you bring more industry, you bring more crime. Several of those businesses along Frontage Rd. have been broken into and it is my backyard. The land is a low-lying ground, and if there is to be any building back there, dirt would have to be brought in. The water flows from the west, and we farm all that ground. I am afraid of

what they would do there like moving the dirt, making a mess of the water since everything is low lying. We have had trouble with drainage, and the water would drain toward our fields and possibly affecting our income.

Both Commissioner Kaup and Dehn asked for clarification of Ms. Meier's land. Ms. Meier stated that her father in law owns much of the land being discussed and it has been in the family for many generations.

With no one else coming forward, Commissioner Dehn declared **the public hearing closed.**

Questions/Comments from Commissioners:

Commissioner Pearson asked how there would be access to the property if the land is not big enough for industrial access? Commissioner Kaup stated they would have to combine the lots of the properties to the north of Highway 24.

Commissioner Kaup stated that the zoning map, if approved, would be consistent with the future land use map and the entire properties west of Vail Ave show as light industrial.

Commissioner Naeger asked if a building were to be developed, that would require filling in lowline areas, would a review by city staff need be done for water runoff? Mr. Hall confirmed that a storm water management plan would need to be submitted during the review of site development plan.

Commissioner Pearson asked if people can make comments about the "look" of the property during the site plan review. Ms. Driver stated that there are standards that need to be addressed regarding aesthetics but it will be up to the administration during the site plan review phase.

Commissioner Nelson asked for clarification regarding the surrounding farm land, and if it was in the purchase process. Mr. Hall stated the land to the north has been rezoned and was authorized by the owner at that time. The land to the south is not apart of this project currently, and the future is unknown. Things are developing around this land as light industrial.

With no further questions from commissioners, Mr. Dehn called for a motion.

Motion by Commissioner Kaup, **second** by Commissioner Herron: **to adopt the findings and analysis in the staff report and to recommend approval to change the zoning of the property from "R-1" Single Family Dwelling District to "I-1" Light Industrial District. Approved 9-0-0**

Commissioner Kaup referenced the current set back requirements (10 feet to the rear and 7 feet side yards) and how they are quite small. Although not an issue for the current case, but he would like the staff's thoughts on a text amendment for the consideration of the Planning Commission.

Public Hearing of PUD23/8 Pizza Hut (Topeka Blvd), a rezoning from “O&I-2” Office and Industrial District to “PUD” Planned Unit Developmental to allow “O&I-2” Office and Institutional uses and a restaurant with drive-through service.

Staff:

Will Sharp presented the staff report and staff’s recommendation of approval.

Questions/Comments from Commissioners:

Commissioner Naeger asked for clarification regarding existing drivers turning left onto Topeka Boulevard. The applicant does not think it’s necessary to restrict to only right turn, and city staff thinks it is best practice to limit to only right turn. If this passed with no amendments, could you turn anyway? Mr. Hall said that a traffic study was not required upon the original submittal. The applicant did submit one, and wishes to have left turning movement on Topeka Boulevard for exiting traffic. The City traffic engineer reviewed this and advised upfront the unlikelihood of the city approving left turning movements for exiting traffic. At this point, the city engineer’s recommendation (and requirement) is that there is to be no left turning movements onto Topeka Boulevard. Mr. Hall also pointed out that there is no verbiage in the staff report stating that, it defers to the traffic study.

Commissioner Naeger asked about the proximity of the exit of the Pizza Hut to a car traveling east on 9th Street, and if those would be within a hundred feet of each other. Mr. Sharp was unable to answer on the exact distance.

Commissioner Kaup also stated concern regarding the curb cut and the street, and asked about the city code. Commissioner Kaup expressed concerns regarding the danger of turning left across two lanes of traffic, and the lack of distance to avoid an accident for someone rolling through the intersection. Mr. Hall stated that if it was a new site to be developed, the city would most likely not allow it. Commissioner Kaup pointed out that a left-hand turn does not have to be continued, and this could be an opportunity for correction if it is considered a traffic hazard. Commissioner Kaup also asked if turning left was “non-conforming”, and Mr. Hall agreed in terms of spacing.

Commissioner Kaup asked about the historical properties, and if environs of the property came into play. Attorney Feighny stated that the state has gone away from the environs review. Commissioner Pearson stated that this building has lost its integrity.

Commissioner Pearson asked if the issue of the lighting was addressed in the site plan. Mr. Sharp stated no, however, the issue of the lighting came up in the neighborhood information meeting regarding security and safety. This will be looked at closer at the site plan review.

Owner’s Representative:

Molly Redmond, C and C

Cody Cohen, Flynn Restaurant Group

Commissioner Naeger asked about the amount of people driving through for pickup vs the amount of people having pizza delivered. Mr. Cohen stated that he didn’t have exact numbers, but there was an independent traffic study done regarding the quantity of traffic from its existing condition to the proposed condition. The proposed Pizza Hut is anticipated to generate fewer peak hours trips than the former bank use. The surrounding roadway network is expected to be no different than the former land use. Based on the capacity analysis performed, proposed development is anticipated to have no significant impact on the operations of the study intersections. The existing proposed site driveway to the southwest Topeka Boulevard currently has adequate site distance and should maintain site triangles that are free of sight obstructions.

Commissioner Kaup asked if the bottom line was that it would be right turn only, south on Topeka Boulevard, does that kill your deal? Mr. Cohen stated that they would prefer it to be left or right to reflect the current use. Although it would not kill the deal, it would significantly impact the store’s capability to service the customers.

Commissioner Kaup asked if there had been any consideration to people turning into the exit, should it remain a left- or right-hand turn. Mr. Cohen stated that there would be signs to put up.

Commissioner Tobaben inquired about the trip generation, and how the problem is more with exiting vehicles conflicting with other vehicles on Topeka Boulevard and pedestrians in the crosswalk. There are very few gaps in Topeka Boulevard traffic allow a left turn, and that may impact the flow of the vehicles through the business. Ms. Redmond stated that they had a full traffic review done by another company, and it helps to elevate some of the concerns. Some one won't wait to turn left, they will turn right if they can't turn left.

Commissioner Hannon asked if deliveries and trash pickups are possible within the site. Ms. Redmond stated that they virtually drove a truck through the site, and the alley will need to be widened at the entrance apron.

Mr. Cohen stated that they would be willing to do what ever was needed to address the lighting concerns.

Commissioner Dehn declared the **public hearing open**.

ShaMecha King Simms, President of Historic Old Town NIA, doesn't believe the overall neighborhood has any issues with the proposal. Ms. King Simms wanted to bring the pedestrian foot traffic to light; there are a lot of high school students walking around on their lunch breaks. There is a lot of bike traffic and flow of pedestrians from people who live in and around that portion of the neighborhood. About turning left and safety, Ms. King Simms believes that needs further consideration. The lighting concerns are for both the employees of the site, and people feeling comfortable utilizing the services. This is a neighborhood first, and there needs to be a balance between the residents and the businesses within the area.

With nobody else coming forward to speak, Commissioner Dehn declared the **public hearing closed**.

Questions/Comments from Commissioners:

Commissioner Kaup emphasized his concern for a left turn off the existing driveway. Mr. Hall stated that per the staff report, the recommendation lies with the city engineer as part of the site development plan. In the traffic report, which was apart of the attached study, the city engineers are opposed to exiting left turns onto Topeka Boulevard. Commissioner Kaup inquired with the current conditions written, if there could be an exit either to the left or right onto Topeka Boulevard. Mr. Hall did state that the Planning Commission could be more specific with their recommendations. Commissioner Kaup asked for language that references the site plan review and how the Planning Commission is concerned about creating a dangerous situation if there is no diverter or reconfiguration of the curb cut.

Commissioner Pearson asked Commissioner Kaup about his concern regarding accidents in that area. Commissioner Pearson stated that the traffic has been that way since the building was built. Commissioner Kaup stated that the building has been vacant for a few years, and there hasn't been any traffic seen in a while. The traffic flow may be different for a restaurant versus a financial institution. Commissioner Pearson stated she could understand the concern if the peak hours would be during the normal workday.

Commissioner Kaup asked about the language in the report that states "diverter". Mr. Sharp explained that Topeka Metro did provide comments recommending a diverter on the exit before the southbound flow of traffic. Commissioner Hannon asked for clarification of the diverter. Mr. Sharp stated that it would prevent the driver from turning left on to Topeka Boulevard, like what you see on Wanamaker.

Lee Holmes, City of Topeka Project Engineer
Brad Johnson, Benesch Traffic Engineer

Commission Kaup asked if there could be a continuation of the left turn off the driveway that would be non-compliance with any city code. Mr. Holmes stated that based on the design criteria there would have to be 250 feet from any intersection for a driveway, and this curb cut is currently 60 feet from a driveway. Although, this curb cut was designed back in the 1960's, Mr. Holmes is not sure why it was allowed. Commissioner Kaup asked if it would not be allowed for traffic safety purposes, and Mr. Holmes confirmed that was correct because it is too close to another intersection. There are also "RRFB" (rapid rectangular flashing beacons) which pedestrians use to cross the street. At one point, there was a lot of pedestrians using that intersection.

Mr. Johnson stated there is a limited property frontage there, and that there is time where they must work with people and landowners to maintain access. If there was no building there, we wouldn't want the driveway there because none of the access management criteria as part of the design criteria is met. We are concerned with allowing "lefts out" there. Gaps will be created and people will try to shoot out of there and then you have pedestrians crossing. We are trying to look out for the safety of the motoring public, the Pizza Hut patrons, and the pedestrian activity in the area.

With no further questions from commissioners, Mr. Dehn called for a motion.

Motion by Commissioner Tobaben, second by Commissioner Nelson to a recommend APPROVAL of the rezoning of "O&I-2" Office and Industrial District to "PUD" Planned Unit Developmental to allow "O&I-2" Office and Institutional uses and a restaurant with drive-through service, based on the findings and subject to the conditions as recommended in the staff report. Approved 9-0-0

Public Hearing of CPA23-01 Historic Holliday Park Neighborhood, The Historic Holliday Park NIA was awarded the 2023 DREAMS I. This is a two-part process with neighborhood planning occurring in 2023 and implementation occurring in 2024 – 2025. The planning stage is coming to completion and is being presented as an update to the Historic Holliday Park Neighborhood Plan process. The NIA has been working with Planning staff since March 8, 2023 to update the 2008 Historic Holliday Park neighborhood plan. The Plan implements portions of the "target area" approach with housing dollars, but not infrastructure projects. The neighborhood opted for an infrastructure approach that provided the greatest benefit to the full neighborhood and most curb appeal.

Staff:

Bryson Risley presented the staff report and staff's recommendation of approval.

Questions/Comments from Commissioners:

Commissioner Pearson asked if there would be any assistance from the City to get the sidewalks ADA compliant. Mr. Risley stated that the 50-50 side walk program is only for the concrete.

Commissioner Naeger inquired about the difference in price for the upkeep of brick versus concrete. Mr. Risley stated that the brick will be costlier to install, maintain, and brick sidewalks will be the responsibility of the property owner.

Commissioner Dehn asked if there were any current brick streets getting paved over, or is it just mill and overlay of existing asphalt. Mr. Risley stated that there is brick underlying on most of the streets. Fillmore between 13th and Huntoon is the only section in this neighborhood that has exposed brick, and that is not being touched at this time. Everything else is going to be the mill and overlay.

Commissioner Kaup asked for clarification if any of the 1.7 million is in the adopted Capital Improvement Plan. Mr. Risley stated that the 1.7 million is included but the specific projects listed here are not in the CIP. There is a budget for these projects, but they are not identified until we adopt the plan. There are 1.7 million funds for projects associated with DREAMS, and now I have outlined in more detail what those projects are.

Commissioner Naeger asked if there was a common thread about the buildings in the areas that were in the roughest shape (such as rental properties owned by out of state corporations). Mr. Risley was not able to provide an exact answer, as it is hard to tell who lives in or maintains the properties.

Commissioner Pearson asked for clarification regarding the "community building and initiatives" aspect of the project, and if this would be coordinated through the neighborhood housing services department or the CAC. Mr. Risley stated that part of the plan is helping to empower the NIA itself. This is to help put ideas and frame work out there; if they need help with something such as community engagement or talking with the police. Commissioner Pearson asked who would oversee this. Mr. Risley stated that generally it would be up to the NIA,

as the city doesn't have the staff to oversee everything. Mr. Risley also explained that he has worked with the NIA and if there are any questions, then they can reach out to him so that he can help build the relationships between the NIA and the City.

Commissioner Dehn declared the **public hearing open**.

Wayne Roberts, President of Historic Holliday Park NIA, stated that there have been a lot of meetings, and the NIA is 100 percent behind this. Although there are a bunch of historical things that the neighborhood would love to have done, the main goal is to get the neighborhood back. How can we spread the wealth, and get as much done as possible? Some really hard decisions were made such as the brick sidewalks. They weren't being maintained, and a lot of them had grass growing over them making them hard to walk on much less ADA compliant. Now you can walk on them and they are ADA complaint. The neighborhood was very involved with how the money was spent.

John Jacobs, 1263 SW Western Ave, there have been a lot of engagement with Bryson and other groups such as the police, Community Engagement, and Parks and Services, to gain a better knowledge of what we have authorization to do, what we can ask for, and what is outside of the City's purview. We made some very hard decisions, but the goal has been to make the neighborhood safe. Not only from violence, but also because the sidewalks are not level enough for walkers or strollers to get across the street. Right now, we don't have community within the neighborhood. We have spent the last year yelling at each other to come to a consensus as trying to build community with the good and the bad.

With nobody else coming forward to speak, Commissioner Dehn declared the **public hearing closed**.

Questions/Comments from Commissioners:

Commissioner Dehn stated that he had a connection to this area from a letter written by his great grandfather to his great aunt.

Commissioner Herron grew up in this area, and is excited to see this project happening.

Commissioner Nelson stated that it was nice to see a community take pride in their community and want to take back ownership.

Commissioner Naeger stated that he was pleased the community got to prioritize their wants.

Commissioner Kaup thought the work was very solid, and glad to hear there was a lot of engagement.

Motion by Commissioner Naeger, **second** by Commissioner Herron **to a recommend APPROVAL of the Historic Holliday Park Neighborhood Plan Update as an element of the City's Comprehensive Plan. Approved 9-0-0**

Communications to the Commission

No meeting in January.

Mary Feighny is retiring.

With no further business appearing, the meeting adjourned at 7:41 PM.

**STAFF REPORT – ZONING CASE
TOPEKA PLANNING DEPARTMENT**

PLANNING COMMISSION DATE: Monday, February 19, 2024

APPLICATION INFORMATION:

CASE NUMBER / NAME: CU23/06 City of Topeka Utilities Department (MTAA Billard Airport Pump Station)

REQUESTED ACTION / CURRENT ZONING: A Conditional Use Permit (CUP) for “Public Utility Facility, Type II” to rebuild and relocate a sanitary sewer pump station on property zoned “R-1” Single-Family Dwelling District. The property already contains an existing Special Use Permit (SU81/21) for a “Public Use Facility” to accommodate a General Aviation Airport, approved in 1981 and remains with the land.

PROPERTY OWNER: Metropolitan Topeka Airport Authority (MTAA)

APPLICANT City of Topeka Utilities Department / Zach Stueve, PE, Project Engineer

APPLICANT REPRESENTATIVE: Angela Sharp, PE, Bartlett & West Inc.

CASE PLANNER: Annie Driver, AICP, Planner II

PROPERTY LOCATION / PARCEL ID: An approximate 0.22 acre easement within Billard Airport property located at 3500 NE Sardou Avenue. The City of Topeka Utilities Department has acquired an easement to replace the aged pump station providing services for the airport terminal (owned by the Metropolitan Topeka Airport Authority).

STAFF RECOMMENDATION: Based upon the above findings and analysis Planning Staff recommends **APPROVAL** to the Governing Body of the Conditional Use Permit CU23/06, subject to conditions stated in the staff report.

RECOMMENDED MOTION: Based on the findings and analysis in the staff report I move to recommend **APPROVAL** to the Governing Body of the Conditional Use Permit CU23/06, subject to conditions stated in the staff report.

PHOTOS:



Photo taken: 1-23-2023

Original airplane hanger and existing pump station building: New site is on the diagonal to the existing pump house building



Photo taken: 1-23-2023

PROJECT AND SITE INFORMATION

PROPOSED USE / SUMMARY:

The City of Topeka Utilities Department is proposing to rebuild and relocate a sanitary sewer pump station constructed as part of Billard Airport around 1940. The existing pump station will be demolished after the new pump station is constructed and in operation. The existing pump station has outlived its life cycle and no longer satisfies minimum KDHE design standards of and needs to be re-built and replaced in order to provide sufficient services to the airport.

The visible and above ground elements of the pump station will include an 80 sq. ft. (8' tall X 10') fiberglass, reinforced plastic control building on a concrete foundation slab with gravel drive and 50' tall telemetry antenna and low pitched roof. The location is just west of the airport's brick limestone airplane hanger and existing pump station, constructed in the same architectural style as the hanger.

DEVELOPMENT / CASE HISTORY:

The subject property has been zoned for single family uses on the basis of being annexed into the City of Topeka in 1969. Billard Airport was constructed in 1940 honoring Phil Billard who made the first flight between Topeka and Kansas City and died in World War II. A Special Use Permit was approved in 1981 allowing the

operation of the public airport for general aviation as a “Public Use Facility”. A “Public Use Facility” is no longer listed a conditional use in the zoning code, but remains tied to the subject property and land. Under the current zoning district, an airport requires a CUP in “R-1” zoning. (SUPs converted to CUPs in 1992 with a comprehensive code update.)

ZONING AND CHARACTER OF SURROUNDING PROPERTIES:

The City of Topeka easement is encompassed within Billard Airport. The subject property and building are compatible with the zoning of surrounding property and with the character and style of surrounding buildings. The re-built sanitary sewer pump station is necessary to provide adequate service for the public airport.

COMPLIANCE WITH DEVELOPMENT STANDARDS AND GUIDELINES

BUILDING HEIGHT & SETBACKS:

Maximum building height in the “R-1” zoning district is 42 feet and the proposed pump station building has a height of 10 ft. Any building, structure, and tower exceeding 42 ft. was approved as part of the original permit for the airport.

TELEMETRY ANTENNA HEIGHT & SETBACKS:

The proposed pump station includes a telemetry antenna, no more than 50 ft. in height to be utilized for the transmission of data required for the remote controlling and monitoring of pump station system performance. Pursuant to TMC 18.230.050 (6) such an antenna shall not exceed 62 feet in height and shall be a minimum distance of 80 percent of the structure’s height from the public right-of-way and adjacent properties. The setback is not an issue in this case since the pump station is entirely contained within the airport’s boundary.

PARKING AND ACCESS:

Access to the pump station site will be from a proposed gravel hard surfaced driveway with access off “Sardou” Avenue; a private street. All streets are private within the airport boundary and maintained by MTAA with the City having no maintenance responsibility..

The Topeka Zoning Ordinance does not include a parking quantity standard for a sanitary sewer pump station. The pump station will receive traffic no more than one time per week for standard maintenance. The gravel lot is sufficient to accommodate one vehicle accessing the site that is needed for maintenance.

LANDSCAPING AND SCREENING:

Planning staff recommended some landscaping be provided, other than turf, but concluded a Landscape Plan is not required because of the compatibility of the above ground structure with surrounding buildings and uses. There is no benefit to adding landscaping since the pump station is of limited size, is located in the center of the airport, and only replaces an existing pump station on site.

SIGNAGE:

The CUP site plan includes a note stating that signage shall be limited to a building mounted wall sign identifying the purpose of the facility. Chapter 18.10 Non-Residential wall signs in the Sign Code indicates the building is permitted 1 wall sign not to exceed 12 sf (1.5 sf per linear foot of frontage).

LIGHTING & SOUND GENERATION:

The CUP site plan includes a note stating that the intensity of any exterior lighting shall be no more than three foot-candles as measured at the property line, and the source of illumination shall not be visible from public right-of-way or adjacent properties.

The CUP site plan also includes a note stating that the ongoing operation of the pump station will generate no sound greater than 50 decibels measured at the property line and this limit shall NOT apply to vehicles for occasional facility and grounds maintenance, use of an emergency generator, temporary station malfunction, or other temporary sources of noise.

DESIGN STANDARDS:

The proposed plastic fiberglass pre-manufactured, fiberglass building is compatible with the surrounding buildings and uses serving the airport.

TMC 18.215.030 – GUIDELINES FOR CUP EVALUATION:

The guidelines relate to development density, height and floor area relative to surrounding structures, setbacks of surrounding structures, building coverage, functionality and safety of parking and circulation, stormwater management, building design, traffic and other operational characteristics, the Comprehensive Plan, and other applicable regulations.

Adherence to guidelines:

- The pump station will generate very little, if any, traffic to the site.
- The building matches the style and character of surrounding buildings.
- Public facilities such as sanitary sewer pump stations are necessary to support a municipal airport. The upgrade to the existing pump station is required by KDHE minimum standards.
- The original pump station was likely constructed in 1940 with Billard Airport. The pump must be reconstructed and modified in this location to sufficiently provide the necessary pumping capacity for the airport and to satisfy minimum KDHE state standards.
- Operations of the pump station will generate no sounds greater than 55 decibels.
- Wall signage, if proposed, will not exceed 12 sq. ft.
- The exhaust system of the new pump station is being designed to accommodate future odor control measures.

PUBLIC FACILITIES

**TRANSPORTATION:
(MTAA)**

The pump station lies within the boundaries of Billard Airport, owned and operated by the Metropolitan Topeka Airport Authority. The airport authority has not expressed any concerns as this pump station is needed to maintain operations of the airport..

OTHER FACTORS

SUBDIVISION PLAT:

The subject property is included within Billard Airport Subdivision.

**FLOOD HAZARDS, STREAM
BUFFERS:**

Zone X- Area of Minimal Flooding. Subject area is levee protected.

UTILITIES:

The property is served by a full range of utilities and services.

TRANSPORTATION/TRAFFIC:

The proposed public utility facility replacement will have no discernable impacts upon traffic within the surrounding area.

HISTORIC PROPERTIES:

Not Applicable

**NEIGHBORHOOD INFORMATION
MEETING:**

At the direction of Planning staff, the applicant did not conduct a Neighborhood Information Meeting because the subject property is the City's easement for the pump station. The notice of the public hearing was sent to owners of property within 200 feet of the easement boundary as required by the City Attorney. Other than Metropolitan Topeka Airport Authority (MTAA), the State of Kansas Highway Patrol is the only owner within 200 feet of the easement boundary. The applicant informed the Kansas Highway Patrol and MTAA and these agencies did not express any concerns. The airport boundary is contiguous to the Oakland NIA boundary. Staff notified the NIA of this change and the NIA President, Kevin Cox, indicated only that the MTAA keep them updated on the timing and phasing of construction.

REVIEW COMMENTS BY CITY DEPARTMENTS AND EXTERNAL AGENCIES

PUBLIC WORKS/ENGINEERING:

No concerns with the CUP

**PUBLIC WORKS/ TRAFFIC
ENGINEERING:**

No concerns with the CUP

WATER POLLUTION CONTROL:

No concerns with the CUP.

FIRE:

No concerns with the CUP

DEVELOPMENT SERVICES: No concerns with approving the CUP. A Site Construction Activity Permit is needed prior to any commencement of subsurface work, grading or land disturbance on the site.

KEY DATES

APPLICATION SUBMITTAL: December 20, 2023

NEIGHBORHOOD INFORMATION NOTICES MAILED: Waived by City staff

LEGAL NOTICE PUBLICATION: January 24, 2024

PROPERTY OWNER NOTICES MAILED: January 26, 2024
(Notice mailed to owners of property within 200 feet of the perimeter of the easement of the pump station.)

STAFF ANALYSIS

EVALUATION CRITERIA: In considering an application for a Conditional Use Permit, the Planning Commission and Governing Body make findings and conclusions with respect to the following pursuant to Topeka Municipal Code Section 18.245.020 in order to protect the integrity and character of the zoning district in which the proposed use is located and to minimize adverse effects on surrounding properties and neighborhood. In addition, all Conditional Use Permit applications are evaluated in accordance with the standards established in the Section 18.215.030 as related to land use compatibility, site development, operating characteristics, and consistency with the Comprehensive Plan.

- 1. The conformance of the proposed use to the Comprehensive Plan and other adopted planning policies:** The proposed CUP for a sanitary sewer pump station lies within an area designated "*Institutional*" by the Oakland Neighborhood Plan (2015) since contained within the boundary of the municipal airport. The plan does not include specific guidelines for the placement of utility pump stations, but there are established land use planning principles that recognize a need for public facilities to provide necessary public service infrastructure that is required to sustain the growth of institutional uses, such as Billard Airport. The Conditional Use Permit will not alter the underlying residential zoning designation for the property, and the sewer pump station does not alter or undermine the primary use of the property.
- 2. The character of the neighborhood including but not limited to: land use, zoning, density, architectural style, building materials, height, structural mass, siting, open space and floor-to area ratio:** The proposed and rebuilt pump station will be in character and style to the majority of the buildings within the boundaries of the airport. The replacement of the aging and outdated pump station is necessary to sustain the existing capacity and services of the municipal airport and the use is in character with the surrounding area
- 3. The zoning and uses of nearby properties, and the extent to which the proposed use would be in harmony with such zoning and uses:** The installation and operation of a pump station is not unusual in a residential zoning district and will be harmonious with the surrounding airport buildings and uses. Pump stations are a vital and essential public infrastructure to sustain the presence of an airport the serves the region.
- 4. The suitability of the property for the uses to which it has been restricted under the applicable zoning district regulations:** The subject property is not suitable for most uses permitted by-right under the site's "R-1" residential zoning, but is suitable for the proposed sewer pump station. The existing zoning of the airport will not change as a result of the CUP, and the CUP establishes standards to ensure compatibility with other surrounding uses and buildings.

5. **The length of time the property has remained vacant as zoned:** The subject property, and easement owned by the City of Topeka, is vacant but is located within the Billard Airport. The Billard Airport was developed in 1940 and subsequently zoned “R-1” Single Family Dwelling District upon becoming part of the City of Topeka in 1969 after the annexation. A Special Use Permit exists allowing Billard Airport as a “Public Use Facility” that was approved in 1981 for a “General Aviation Airport”. The replacement of the existing pump station is necessary to maintain the airport.
6. **The extent to which the approval of the application would detrimentally affect nearby properties:** The pump station will have no discernible negative effects on surrounding uses as it is intended to replace and upgrade the aging pump station on the property. There are notes added to the CUP site plan to address any concerns with odor and noise after operation commences.
7. **The extent to which the proposed use would substantially harm the value of nearby properties:** Based on the low intensity of the proposed use and its replacement of the existing pump station, the proposed use will not harm the value of nearby properties. Rather, it may improve surrounding properties in the neighborhood if it encourages and promotes use of the airport.
8. **The extent to which the proposed use would adversely affect the capacity or safety of the portion of the road network influenced by the use, or present parking problems in the vicinity of the property:** The proposed use will generate very few additional vehicles trips as will only be required for routine maintenance of the facility and will have no discernible impact on the road network, which is privately maintained by the MTAA.
9. **The extent to which the proposed use would create excessive air pollution, water pollution, noise pollution or other environmental harm:** The proposed pump station has a minimal impact. It does not generate air or water pollution, and the noise it generates will be minimal (no greater than 55 decibels). The increase in impervious surface should be negligible to stormwater runoff and a stormwater management plan is not being required by Utilities. With the new sanitary sewer pump station construction technologies, the pump station is anticipated to have very little if any odor impacts on adjacent properties, but is designed to include odor controls if needed. The City of Topeka Utilities Department will maintain the pump station itself.
10. **The economic impact of the proposed use on the community:** Utility pump stations are a vital and necessary component of the community and therefore have a positive economic impact on this neighborhood and the community at-large. Pump stations serve an important function for the general public as do other forms of public infrastructure (roads, sewer, water, electric, gas) and are vital to a continued growth and to sustain the presence of the public airport.
11. **The gain, if any, to the public health, safety and welfare due to denial of the application as compared to the hardship imposed upon the landowner, if any, as a result of denial of the application:** There is no apparent gain to the public health, safety and welfare by denial of the application since approval of the application is necessary to maintain public health, safety, and welfare of the community and full operations of the airport.. The applicant has demonstrated the need to re-construct this pump station in this location. Denial would impose a significant hardship on the landowner since there are no other available sites that suit the needs required for this particular pump station. Additionally, the City of Topeka has already acquired the property as an easement and finding and obtaining another site to serve the airport would be a financial burden and hardship to the City, even if it were possible based on the site’s physical characteristics.

STAFF RECOMMENDATION:

RECOMMENDATION: Based upon the above findings and analysis, Planning staff recommend **APPROVAL**

RECOMMENDED MOTION: Based on the findings and analysis in the staff report I move to recommend **APPROVAL** to the Governing Body of the Conditional Use Permit CU23/06, subject to:

1. Use and Development of the site in accordance with the approved site plan and operational statement for #CU23/06 – City of Topeka Utilities Department (Billard Pump Station MTAA).

Attachments:

- Site Plan
- Aerial Map
- Zoning Map
- Future Land Use Map

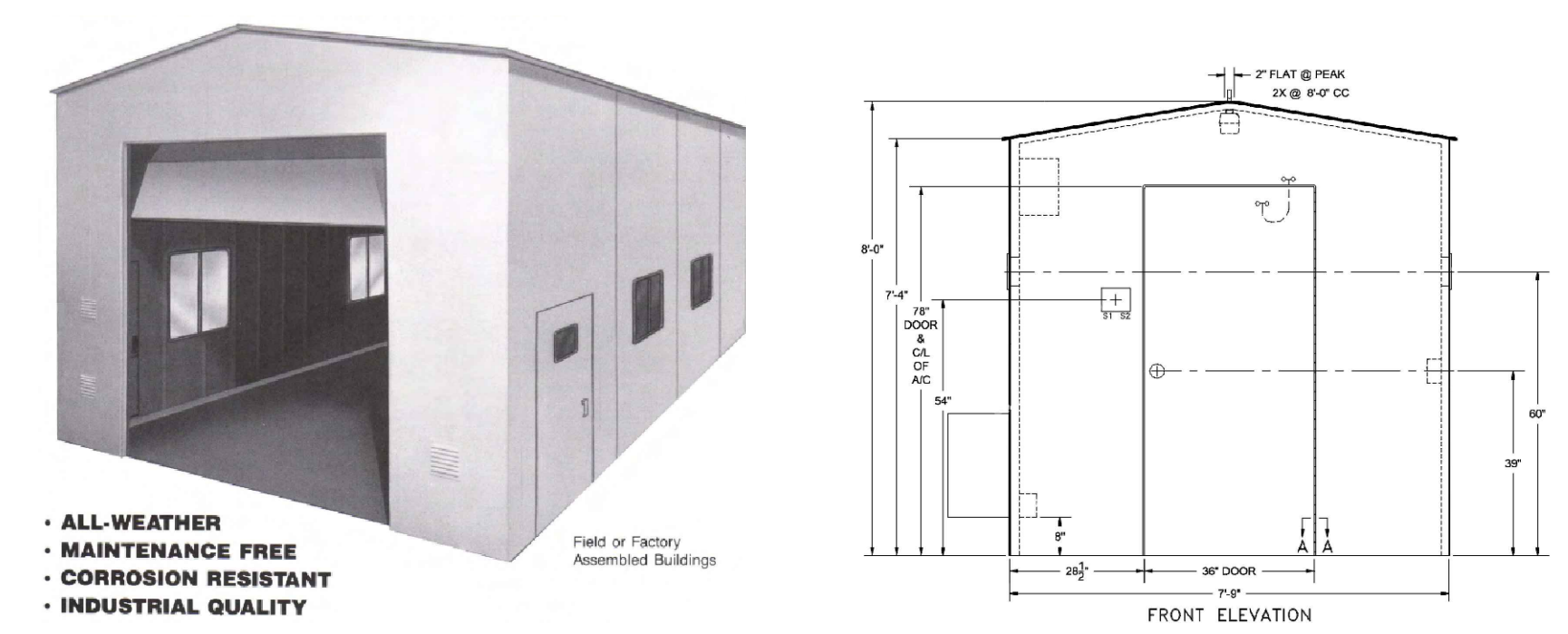
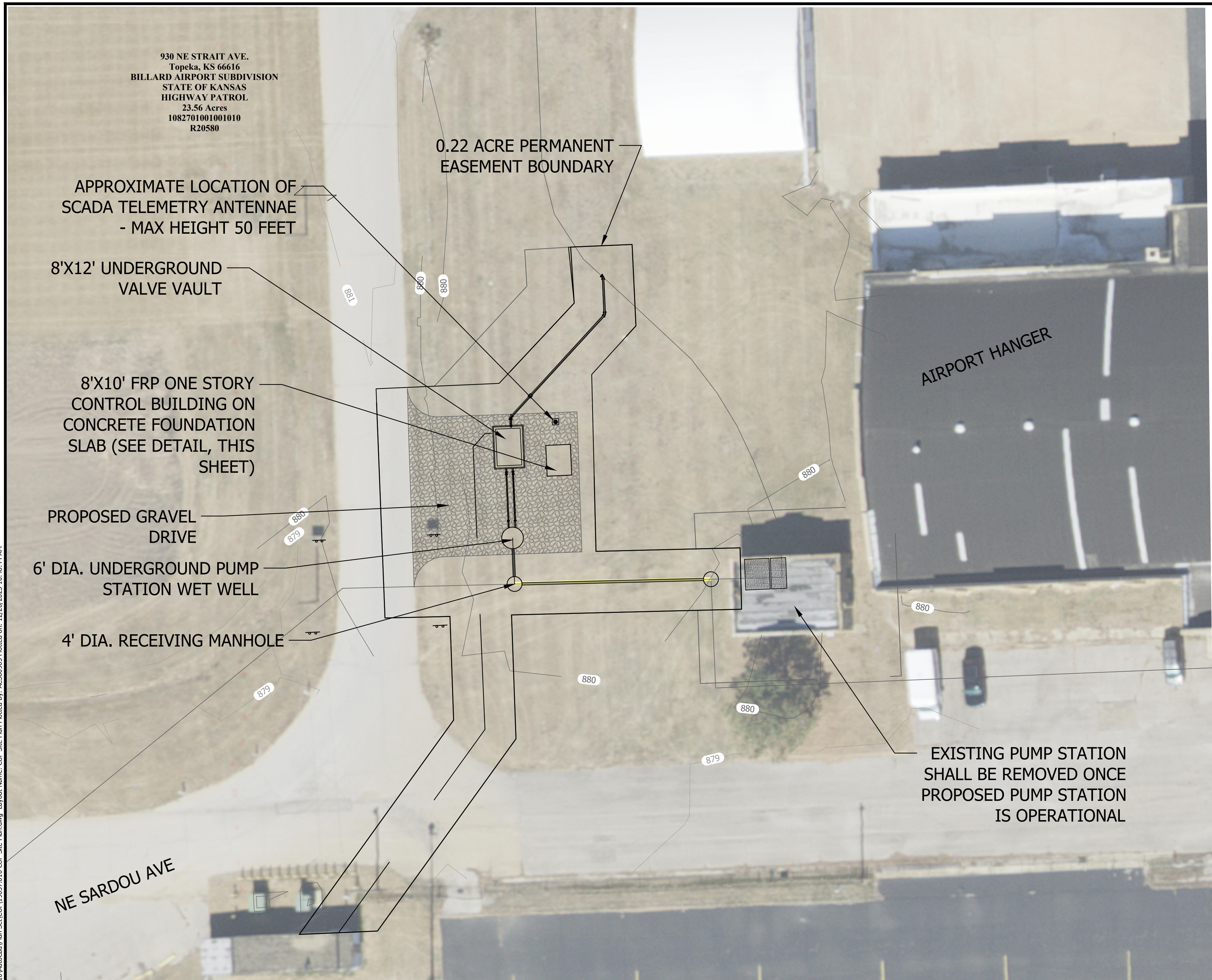

FIBERGLASS REINFORCED PLASTIC BUILDING
(Control Building with south facing door)

STATEMENT OF OPERATIONS

- Existing Zoning: R1 - Residential
No changes in zoning are proposed.
- Property Description:

A PORTION OF LOT 1, BLOCK 'A', BILLARD AIRPORT SUBDIVISION, RECORDED IN PLAT BOOK:30, PAGE:4, RECORDED IN THE OFFICE OF THE SHAWNEE COUNTY REGISTER OF DEEDS, TOPEKA, KANSAS, SITUATED IN THE NORTHWEST QUARTER OF SECTION 27, TOWNSHIP 11 SOUTH, RANGE 16 EAST OF THE SIXTH PRINCIPAL MERIDIAN, IN THE CITY OF TOPEKA, SHAWNEE COUNTY, KANSAS, DESCRIBED BY STEPHEN I. MARINO, II, PS 1380, ON SEPTEMBER 14, 2022, MORE PARTICULARLY DESCRIBED AS FOLLOWS:

COMMENCING; AT THE SOUTHWEST CORNER OF THE NORTHWEST QUARTER OF SECTION 27, TOWNSHIP 11 SOUTH, RANGE 16 EAST OF THE SIXTH PRINCIPAL MERIDIAN; THENCE, COINCIDENT WITH THE WEST LINE OF SAID NORTHWEST QUARTER, ALSO BEING THE WEST LINE OF LOT 1, BLOCK 'A', BILLARD AIRPORT SUBDIVISION, RECORDED IN PLAT BOOK:30, PAGE:4, RECORDED IN THE OFFICE OF THE SHAWNEE COUNTY REGISTER OF DEEDS, TOPEKA, KANSAS, NORTH 00 DEGREES 11 MINUTES 23 SECONDS EAST, A DISTANCE OF 771.31 FEET; THENCE DEPARTING SAID WEST LINE, SOUTH 88 DEGREES 57 MINUTES 11 SECONDS EAST, A DISTANCE OF 1331.82 FEET TO THE POINT OF BEGINNING

THENCE NORTH 00 DEGREES 12 MINUTES 58 SECONDS EAST, A DISTANCE OF 74.72 FEET; THENCE NORTH 89 DEGREES 58 MINUTES 30 SECONDS EAST, A DISTANCE OF 40.11 FEET; THENCE NORTH 45 DEGREES 31 MINUTES 29 SECONDS EAST, A DISTANCE OF 35.78 FEET; THENCE NORTH 01 DEGREES 07 MINUTES 22 SECONDS WEST A DISTANCE OF 18.28 FEET; THENCE NORTH 90 DEGREES 00 MINUTES 00 SECONDS EAST, A DISTANCE OF 20.03 FEET; THENCE SOUTH 00 DEGREES 12 MINUTES 41 SECONDS EAST, A DISTANCE OF 26.54 FEET; THENCE SOUTH 44 DEGREES 47 MINUTES 40 SECONDS WEST, A DISTANCE OF 21.39 FEET; THENCE SOUTH 01 DEGREES 02 MINUTES 49 SECONDS WEST, A DISTANCE OF 57.64 FEET; THENCE SOUTH 88 DEGREES 57 MINUTES 11 SECONDS EAST, A DISTANCE OF 46.89 FEET; THENCE SOUTH 01 DEGREES 02 MINUTES 49 SECONDS WEST, A DISTANCE OF 20.00 FEET; THENCE NORTH 88 DEGREES 57 MINUTES 11 SECONDS WEST, A DISTANCE OF 74.89 FEET; THENCE SOUTH 00 DEGREES 26 MINUTES 51 SECONDS WEST, A DISTANCE OF 40.37 FEET; THENCE SOUTH 38 DEGREES 12 MINUTES 29 SECONDS WEST, A DISTANCE OF 77.04 FEET; THENCE SOUTH 89 DEGREES 45 MINUTES 09 SECONDS WEST, A DISTANCE OF 25.54 FEET; THENCE NORTH 38 DEGREES 12 MINUTES 29 SECONDS EAST, A DISTANCE OF 86.01 FEET; THENCE NORTH 00 DEGREES 26 MINUTES 51 SECONDS EAST, A DISTANCE OF 33.80 FEET; THENCE NORTH 88 DEGREES 57 MINUTES 11 SECONDS WEST, A DISTANCE OF 21.15 FEET TO THE POINT OF BEGINNING
- Parcel Size: 0.22 acres (9,609 Square Feet)
Maximum Building Footprint: 80 Square Feet
Maximum Building Height: One Story
- Owner:
City of Topeka
215 SE 7th Street
Topeka, Kansas 66603
- Civil Engineer & Plan Preparer:
Bartlett & West, Inc.
1200 SW Executive Dr.
Topeka, KS 66451
- The existing pump station is past its expected life and does not meet the KDHE Minimum Standard of Design for Water Pollution Control Facilities, so replacement of the station is required.
Current Use of permanent easement area:
Vacant area within airport grounds.
Proposed Use of permanent easement area:
Public Utility Facility (Wastewater Pump Station)
City of Topeka - Billard Pump Station
- Personnel and vehicular access is limited to periodic maintenance and operations visits that may occur once per week.
- Boundary information taken from survey performed by Bartlett & West, February and March, 2022.
- Proposed site paving to be gravel.
- Parking Information:
Required Parking = 1 Stall
Proposed Parking Provided = 1 gravel stall
- One wall sign shall be permitted not to exceed a maximum of 12 sq. ft. Free standing signage shall comply with 'R-2' zoning sign standards for incidental free standing signs. Separate sign permit applications are required from the City of Topeka Development Services Division except where exempted from permit requirements by code.
- The owner will coordinate the use of a Knox Box, Key or Code with the Fire Department so that they may have access all times.
- Signage shall be limited to a building mounted wall sign identifying the purpose of the facility.
- Any fencing proposed for the site shall require a fence permit from the City of Topeka.
- The intensity of any parking lot lighting shall be no more than three foot-candles as measured at the property line. The source of illumination shall not be visible from public rights-of-way or adjacent residential properties.
- Ongoing operation of the pump station will generate no sound greater than 55 decibels measured at the property line. The sound limit on ongoing operation does not apply to vehicles for occasional facility and grounds maintenance, use of an emergency generator, temporary station malfunction, or other temporary sources of noise.
- Maximum height of telemetry antennae is 50 feet.
- Building setbacks not meeting the setbacks required by the City of Topeka zoning regulations TMC 18.60 require approval of variances from the Topeka Board of Zoning Appeals. Variances approved by the Board of Zoning Appeals shall be recorded with the Office of the Shawnee County Register of Deeds.
- There shall be no discernible odors emitting beyond the property lines. Odor control measures shall be provided if there are complaints from surrounding residents and property owners.
- The R-1 subject parcel zoning use group does not have a requirement for landscape plantings, there are no existing trees being removed and the proposed 80 SF single story control building is very similar in appearance to a number of the existing buildings in its proximity. That being the case, no landscape plantings are required or proposed with these pump station improvements.

Last edit on: 12/20/2023 10:47 AM by: ACS090665 Drawing Name: W:\Proj\190001\9637\19637_010\AutoCAD\Plan_Sets\CUP\19637_010\CUP_Site_Plan.dwg Layout Name: CUP_Site_Plan_Plot.dwg Plotted on: 12/20/2023 10:48:44 AM

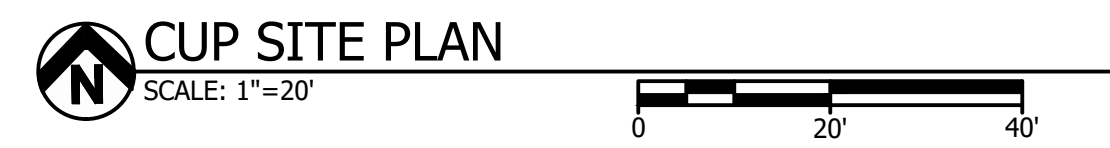

BY	DATE	DESCRIPTION

Bartlett & West

1200 SW EXECUTIVE DRIVE - TOPEKA KS 66616.3880
PHONE 785.272.2200 FAX 785.272.2205
www.bartlettwest.com

CUP SITE PLAN

**BILLARD PUMP STATION IMPROVEMENTS
CONDITIONAL USE PERMIT
TOPEKA, KS**

DESIGNED BY:	EPM
DRAWN BY:	ACS
APPROVED BY:	ACS
DESIGN PROJ:	19637.010
CONST PROJ:	----
SCALE:	AS NOTED
DATE:	DECEMBER 2023
DRAWING NO:	CU23/06
SHEET NO:	1 of 1

ALL RIGHTS RESERVED. ALL BARTLETT & WEST PLANS, SPECIFICATIONS AND DRAWINGS ARE PROTECTED UNDER COPYRIGHT LAW, AND NO PART MAY BE COPIED, REPRODUCED, DISPLAYED PUBLICLY, USED TO CREATE DERIVATIVES, DISTRIBUTED, STORED IN A RETRIEVAL SYSTEM OR TRANSMITTED IN ANY FORM BY ANY MEANS WITHOUT PRIOR WRITTEN PERMISSION OF BARTLETT & WEST.



CU23/06 By: City of Topeka Utilities (Billard Airport / MTAA)



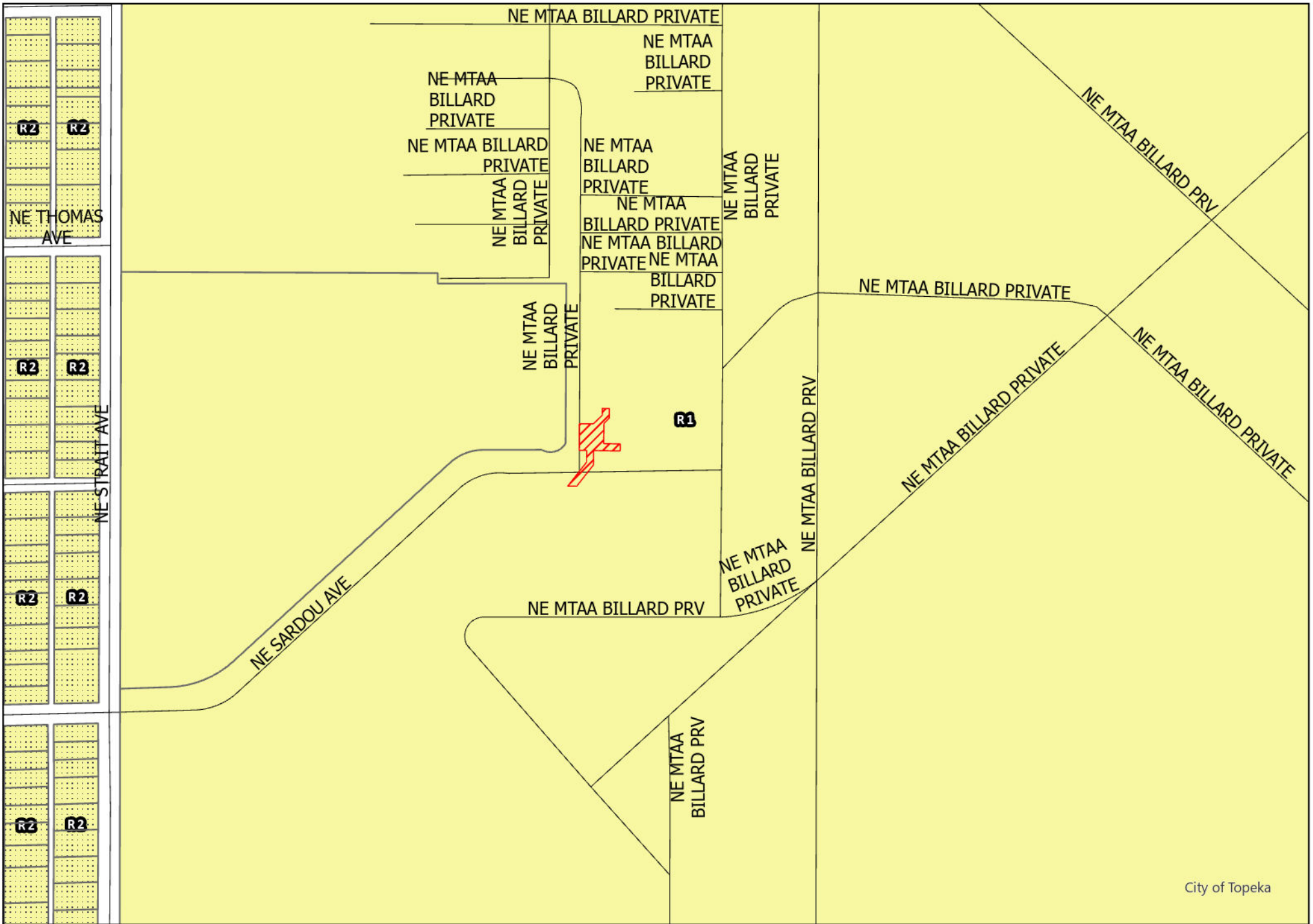

CU23/06 By: City of Topeka Utilities (Billard Airport / MTAA)



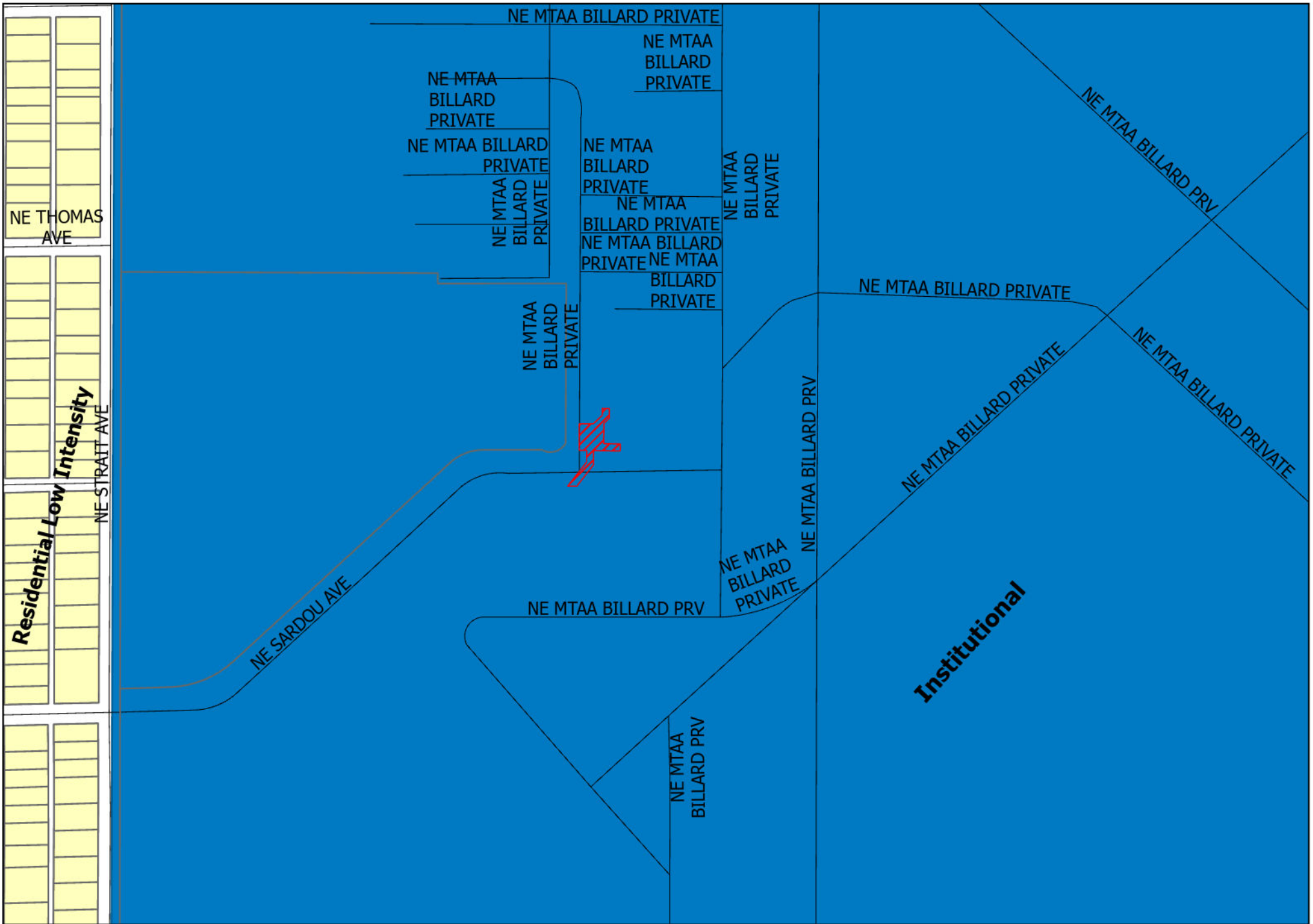

CU23/06 By: City of Topeka Utilities (Billard Airport / MTAA)



STAFF REPORT - SUBDIVISION

City of Topeka Planning Department

Preliminary Plat Phase

Preliminary and Final Plat

Final Plat Phase

RECOMMENDATION: Based upon the findings and staff analysis below, the Planning & Development Department recommends the final plat phase Southland Subdivision No. 3 be **APPROVED** and forwarded to the City Council for its acceptance of land to be dedicated for public purposes, subject to the conditions in the staff report below.

RECOMMENDED MOTION: I move to forward approval of the final plat for Southland Subdivision No. 3 to the Governing Body for acceptance of land to be dedicated for public purposes subject to the conditions in the staff report.

NAME: Southland Subdivision No. 3 [P23/16]

OWNER/DEVELOPER: Excel Development Group

ENGINEER/SURVEYOR: SBB Engineering LLC/ Joshua Bielinski P.E.; Patrick Leo LaFontaine, P.S.

STAFF: Bryson Risley, Planner II

GENERAL LOCATION: located to the northeast of SE 38th Street and SE Colfax Place

PARCEL ID NUMBERS: 1341901001005000, 1341901001005010, 1341901001005020, 1341901001005030, 1341901001005040, and 1341901001005050

JURISDICTION: Class "A" Subdivision – within the corporate limits of the City of Topeka

ANNEXATION: N/A

Area	# of Lots	Residential Density	Proposed Land Use	Zoning
4.73 (w ROW) 3.96 (w/o ROW)	2 lots & 2 tracts	6.7 units per acre	Duplexes	"PUD" M-1 Two-family dwelling district

Zoning Case: N/A (Previous Case Z86/06A – Rezoned Property to "PUD" with M-1 use group.)

Design: This plat is on the northeast corner of SE Colfax Place and SE 38th Street comprising 4.73 acres. The final plat provides the dedication of right-of-way, not previously dedicated in Southland Subdivision No. 2 (P23-08). The dedicated right-of-way is for SE Etzel Avenue, a portion of SE Bryant Street, and utility easements, previously recorded as Tract A in Southland Subdivision No. 2. The plat consists of two lots running east to west along SE Etzel Avenue that will contain eight duplexes (16 units), one lot containing 8 duplex units running north to south along SE Bryant Street and one clubhouse. There is a stormwater drainage tract that runs north to south along SE Colfax Place.

BACKGROUND: This is the preliminary and final plat for Southland Subdivision No. 3. The lot and tract to the east were

previously platted as Southland Subdivision Number 2. The original plat for Southland Subdivision No. 2 subdivided the property into three lots and three tracts. This plat dedicates a portion tract C, which contains an access and utility easement, as right-of-way. The remaining section of SE Bryant Street, running north to south, will remain privately owned and maintained.

NEIGHBORHOOD INFORMATION MEETING:

A neighborhood information meeting was not held because this is a replat of Southland Subdivision No. 2, which was completed as a minor plat, and is consistent with the proposal shown at a prior NIM. A neighborhood information meeting was held November 29th, 2022 as part of the rezoning to “PUD” with “M-1” two-family use group. At that meeting neighbors were informed as the intent to develop the site for senior duplexes.

SERVICES AND FACILITIES:

1. WATER SERVICE: The subdivision will be served by City of Topeka public water supply via an 8” water main to be extended at the expense of the developer as part of developer financed project approved by the City Engineer.
2. SEWAGE DISPOSAL: The subdivision will be served via an 8” City of Topeka sanitary sewer main to be extended at the expense of the developer as part of a developer financed project approved by the City Engineer.
3. WASTEWATER PLAN SERVICE AREA: The property is located within the Urban Service Area (city limits) of the Land Use and Growth Management Plan -2040, which requires service by a sanitary sewer system. In this respect, the proposal is in full compliance with said Plan.
4. DRAINAGE CONDITIONS: The Stormwater Management Plan was submitted by the consultant with the final plat of Southland Subdivision No. 2. One existing stormwater management and drainage easement, identified as Tract B, Block A is located on Southland Subdivision No. 2. An additional stream buffer easement (Type II) and drainage easement in Tract A are carried over from Southland Subdivision No. 2 to Southland Subdivision No. 3.
5. STREET PLAN/ACCESS: The preliminary street plans for the development of SE Bryant Street and SE Etzel Avenue, as submitted by the developer to the City of Topeka Public Works Department, have been approved. The street plan provides 60’ of right-of-way for SE Etzel Avenue and the section of SE Bryant Street that connects to SE 38th Street. The plat will connect to the existing SE 38th Street to the south and SE Colfax Place.
6. FIRE DISTRICT: City of Topeka Fire Department. Additional fire hydrants will be provided as needed with the water main extensions.
7. STREAM BUFFER: The subdivision is impacted by a Type II stream buffer crossing lot 1 of Block A and Tract A.
8. SCHOOL DISTRICT: USD No. 501 – Topeka Public Schools
9. PARKS/OPEN SPACE: Southland Subdivision No. 3 is located within the east parkland fee area, which has a dedication fee of \$75 per dwelling unit and is collected at the time of building permits for each new residential lot.

WAIVER/VARIANCE TO STANDARDS: A variance has been granted to the utility easement standards along the length of the subdivision boundary per TMC 18.40.120. This was determined as the property is already served by utilities on the south side of Lot 1 Block B. Additional utilities will be provided within the street right-of-way of the subdivision.

CAPITAL IMPROVEMENT PLAN (CIP): SE Adams Street between SE 37th Street and SE 38th Street is designated in the CIP for expansion to three lanes and may require additional right-of-way. Anticipation of right-of-way acquisition has been accounted for. No other pending City projects impact the subdivision plat.

CONFORMANCE TO COMPREHENSIVE PLAN: The subject property is identified for Neighborhood Commercial Small as described by the Land Use and Growth management Plan – 2040. The Land Use and Growth management Plan – 2040 plan describes these as areas that contain 1-10 acres of land area and draw traffic from a single neighborhood. The property was recently rezoned to PUD with “M-1” two-family residential use and acts as a transition zone from the commercial uses to the north and the single-family neighborhood to the south and west. The plat reconfirms City Planning Staff’s approval of the minor plat Southland Subdivision # 2 (P23/08) but Southland Subdivision #3 provides the right-of-way necessary for SE Etzel Avenue and a portion of SE Bryant Street to become a public roadway.

STAFF ANALYSIS: The subdivision design and residential density are compatible with the previously platted Southland Subdivision #2. Based upon the above findings and analysis, staff recommends Southland Subdivision #3 be **APPROVED** and forwarded to the City Council for its acceptance of land to be dedicated for public purposes.

Attachments:

Aerial Map
Preliminary Plat -Southland Subdivision #3
Final Plat- Southland Subdivision #3

P23-16 Southland Subdivision #3



City of Topeka Planning Division



Subject Property



Aerial Map

SNCO GIS

PRELIMINARY PLAT

SOUTHLAND SUBDIVISION NO. 3

A REPLAT OF LOTS 1 & 3, AND TRACTS A & C, BLOCK 'A', SOUTHLAND SUBDIVISION NO. 2, CITY OF TOPEKA, SHAWNEE COUNTY, KANSAS.

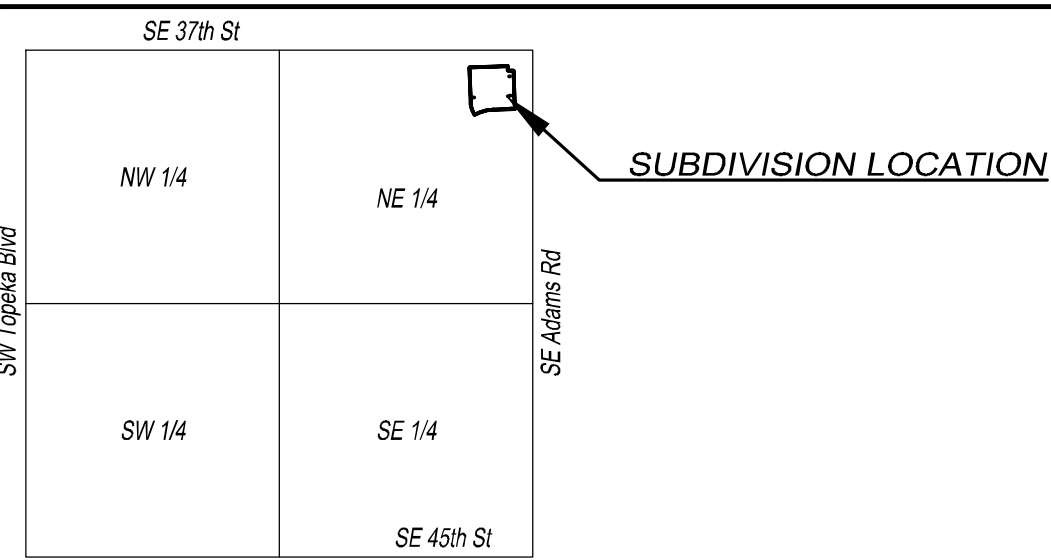

SEC. 19, T12S, R16E
LOCATION MAP
(NTS)

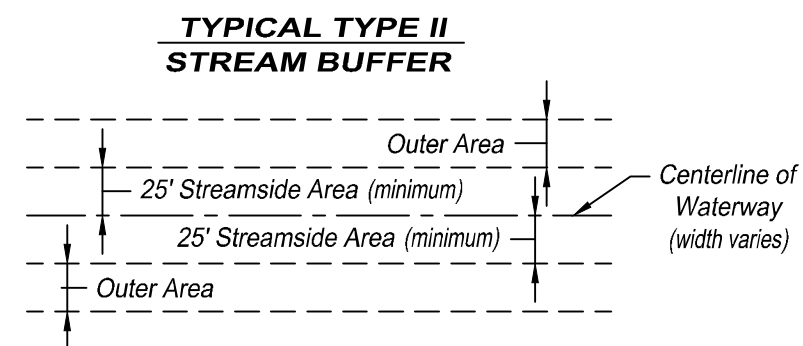

WATERWAY BUFFERS

	STREAMSIDE AREA			OUTER AREA		
	Type I	Type II	Type III	Type I	Type II	Type III
Width	50 feet	25 feet	15 feet	Determined by the GIS-Based Stream Buffer Shapefiles for the City of Topeka		
Vegetation	Native vegetation			Native vegetation or managed lawn (type II or III)		
Uses	Streambank stabilization, flood control, utility corridors			Biking/hiking paths, flood control, detention/retention structures, utility corridors, stormwater BMPs, residential yards, landscape area		
Function	Protect the physical and ecological integrity of the stream ecosystem			Protect key components of the stream and filter and slow velocity of water runoff		

General Notes:

- Property owners shall be admonished from placing any permanent or semi-permanent obstruction in permanent sewer, drainage or utility easements. This includes, but is not limited to, trees, shrubs, fences, retaining walls, buildings or other miscellaneous obstructions that interfere with access or egress of maintenance vehicles or equipment for the operation and maintenance of the utilities or pipe lines located in the easement. Any permanent or semi-permanent obstruction located in the permanent sewer or utility easement may be removed by personnel representing the governing body, to provide for the proper operation and maintenance of that utility line, without cost or obligation for replacement, cost of removal, and/or replacement shall be the responsibility of the property owner.
- Water service will be provided by The City of Topeka Water Department.
- Sanitary Sewer service will be provided by The City of Topeka Public Sanitary Sewer system.
- Minimum opening elevations shall be 1 ft above the highest adjacent 100-year water surface elevation.
- No building permit(s) shall be issued until all Stormwater Management requirements set forth in the Topeka Municipal Code (TMC) are met, including approval of Stormwater Management Plan, granting of any necessary stormwater management, drainage or stream buffer easements, and construction and inspection of all stormwater management facilities contained in the approved Stormwater Management Plan for each phase as applicable.
- No building permits shall be issued until arrangements for the installation of water mains and/or connection charges have been made with the City of Topeka Water Department.
- No building permit will be issued until the owner has made arrangements for connection to public sanitary sewer to serve lot(s) requiring building permits.
- All utilities shall be placed underground pursuant to the City's right-of-way management standards.
- Tracts A and B are intended for nonresidential uses and no building permits shall be issued.
- A Stormwater Management & Drainage Easement is hereby granted over the portions of Tract A that are not encompassed by the Stream Buffer Easement, as shown on this plat. An Access & Utility Easement is hereby granted over the entirety of Tract B.
- Variance(s) Granted:
It has been deemed that utility easements along the length of the subdivision boundary per TMC 18.40.120 are not necessary due to the utility services already exist, unless otherwise shown.
It has been deemed that radius for the center of street per C.O.T. Design Criteria Section 1.2.3 can be reduced due to the existence of the approved site design.
- According to "FIRM" Map Community Panel Numbers 20177C0218E and 20177C0306E effective September 29, 2011 this property is in Flood Zone X, area of minimal flood hazard.

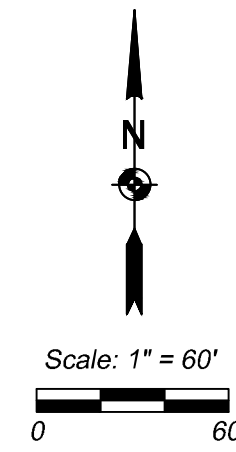
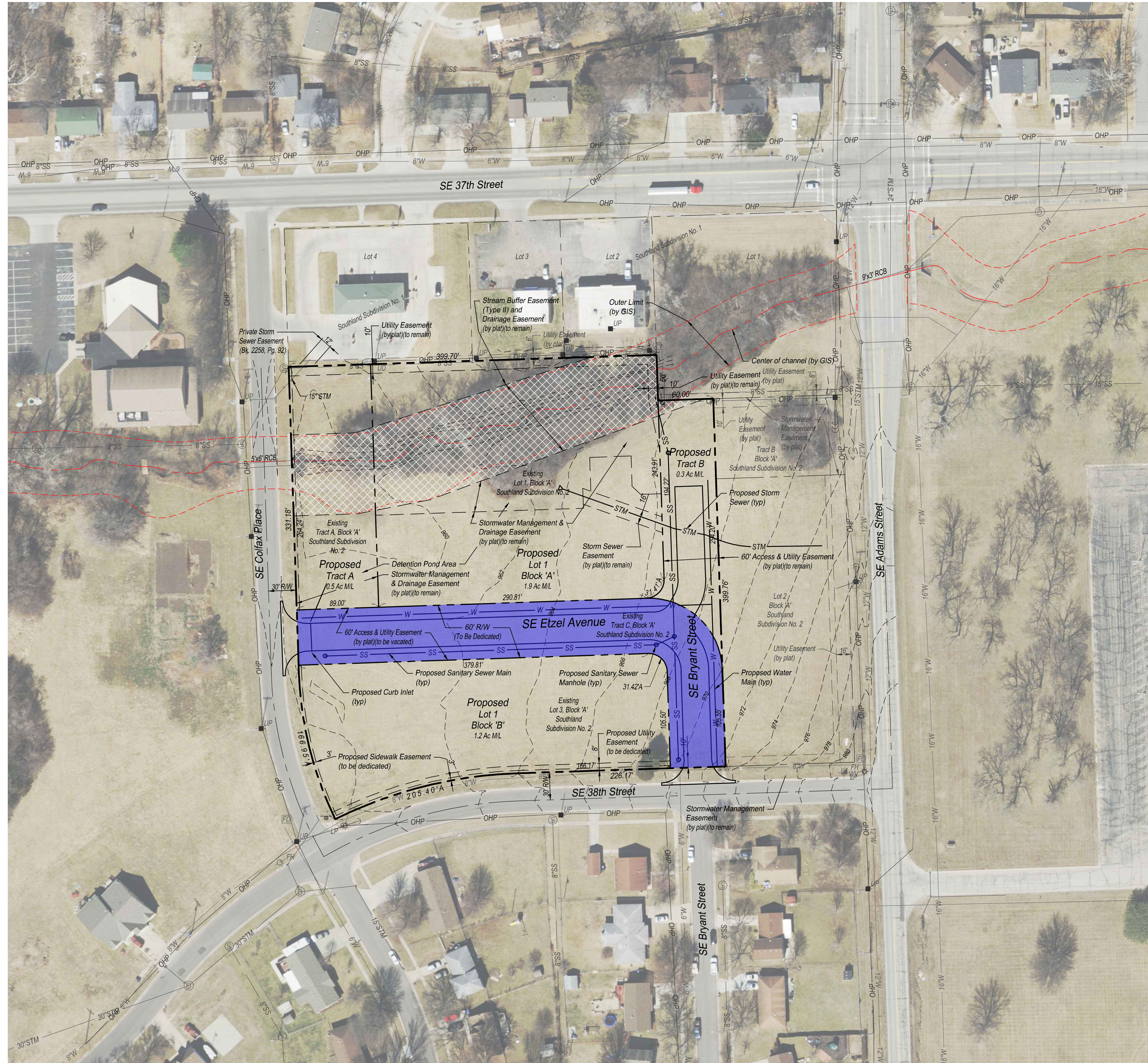

Basis of Bearing:
The bearings shown on this survey are based on the Final Plat of Southland Subdivision No. 2.

LEGEND

- Existing Overhead Power Line
- Existing Water Line
- Existing Sanitary Sewer
- Existing Storm Sewer
- Easement to be vacated by this plat
- Proposed Water Line
- Proposed Sanitary Sewer
- Proposed Storm Sewer

Legal Description:
A replat of Lots 1 & 3, and Tracts A & C, Block 'A', Southland Subdivision No. 2, City of Topeka, Shawnee County, Kansas.

Rev.	By	Date	Description
1	JEM	2/20/2024	Lot layout & staff comments

PREPARED FOR:
Architectural Design Associates
P.O. Box 3410 "C" Street, Ste. A
Lincoln, Nebraska 68510

SBB Engineering, LLC
transportation-site development - surveying
101 South Kansas Avenue
Topeka, Kansas 66603
Ph: (785) 215-8630 / www.sbbeng.com



SHEET TITLE: **PRELIMINARY PLAT**
PROJECT LOCATION: **NW Corner Of The Intersection
SE Adams Street & SE 38th Street
Topeka, Kansas 66605**

SBB Proj. No.:	22-167-1
Drawn by:	JEM
Checked by:	PLL
Date:	7/20/2023
Sheet No.:	

FINAL PLAT

SOUTHLAND SUBDIVISION NO. 3

A REPLAT OF LOTS 1 & 3, AND TRACTS A & C, BLOCK 'A', SOUTHLAND SUBDIVISION NO. 2, CITY OF TOPEKA, SHAWNEE COUNTY, KANSAS.

BOOK _____ PAGE _____
DATE _____ TIME _____

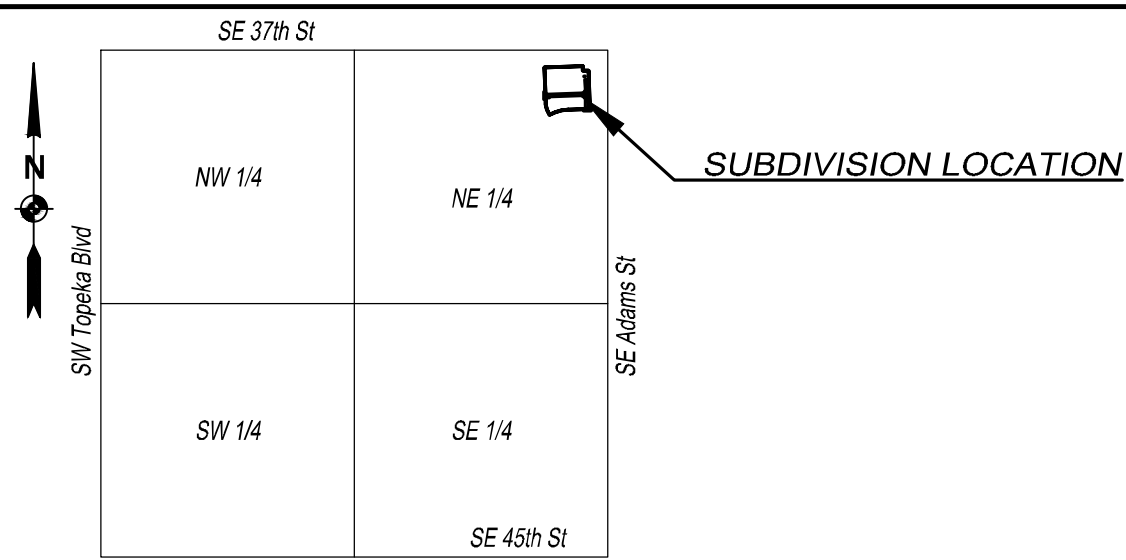

SEC. 19, T12S, R16E
LOCATION MAP
(NTS)

TYPICAL TYPE II STREAM BUFFER

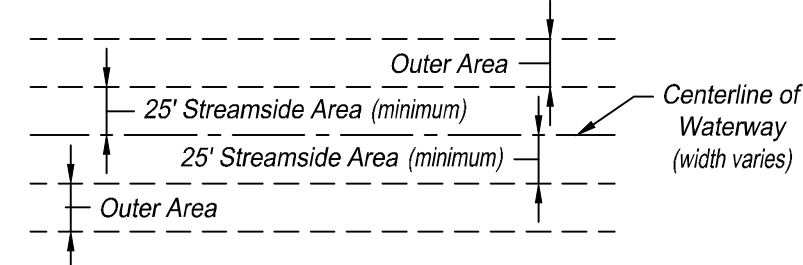

WATERWAY BUFFERS

	STREAMSIDE AREA			OUTER AREA		
	Type I	Type II	Type III	Type I	Type II	Type III
Width	50 feet	25 feet	15 feet	Determined by the GIS-Based Stream Buffer Shapefiles for the City of Topeka		
Vegetation	Native vegetation			Native vegetation or managed lawn (Type II or III)		
Uses	Streambank stabilization, flood control, utility corridors			Biking/hiking paths, flood control, detention/retention structures, utility corridors, stormwater BMPs, residential yards, landscape area		
Function	Protect the physical and ecological integrity of the stream ecosystem			Protect key components of the stream and filter and slow velocity of water runoff		

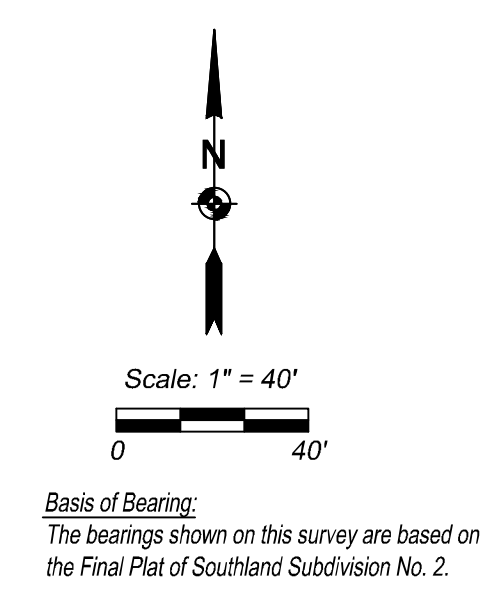
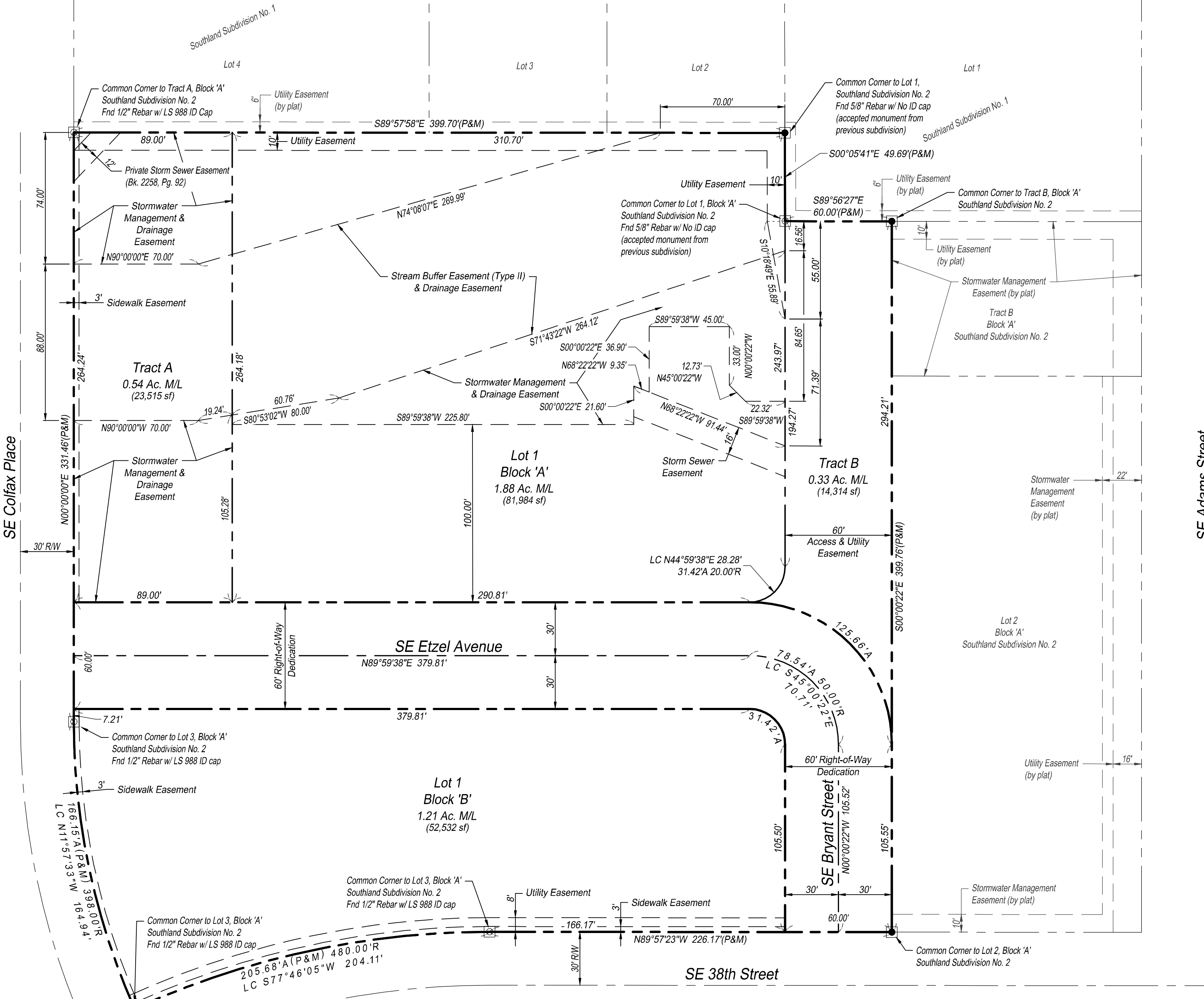

LEGEND

- Found Rebar in concrete, as noted
- Set 1/2"x24" Rebar w/ SBB ENG CLS 263 ID Cap, in concrete
- (P) Plat
- (M) Measured

- General Notes:**
- Property owners shall be admonished from placing any permanent or semi-permanent obstruction in permanent sewer, drainage or utility easements. This includes, but is not limited to, trees, shrubs, fences, retaining walls, buildings or other miscellaneous obstructions that interfere with access or egress of maintenance vehicles or equipment for the operation and maintenance of the utilities or pipe lines located in the easement. Any permanent or semi-permanent obstruction located in the permanent sewer or utility easement may be removed by personnel representing the governing body, to provide for the proper operation and maintenance of that utility line, without cost or obligation for replacement, cost of removal, and/or replacement shall be the responsibility of the property owner.
 - Water service will be provided by The City of Topeka Water Department.
 - Sanitary Sewer service will be provided by The City of Topeka Public Sanitary Sewer system.
 - Minimum opening elevations shall be 1 ft above the highest adjacent 100-year water surface elevation.
 - No building permit(s) shall be issued until all Stormwater Management requirements set forth in the Topeka Municipal Code (TMC) are met, including approval of Stormwater Management Plan, granting of any necessary stormwater management, drainage or stream buffer easements, and construction and inspection of all stormwater management facilities contained in the approved Stormwater Management Plan for each phase as applicable.
 - No building permits shall be issued until arrangements for the installation of water mains and/or connection charges have been made with the City of Topeka Water Department.
 - No building permit will be issued until the owner has made arrangements for connection to public sanitary sewer to serve lot(s) requiring building permits.
 - All utilities shall be placed underground pursuant to the City's right-of-way management standards.
 - Tracts A and B are intended for nonresidential uses and no building permits shall be issued.
 - A Stormwater Management & Drainage Easement is hereby granted over the portions of Tract A that are not encompassed by the Stream Buffer Easement, as shown on this plat. An Access & Utility Easement is hereby granted over the entirety of Tract B.
 - Variance(s) Granted:
It has been deemed that utility easements along the length of the subdivision boundary per TMC 18.40.120 are not necessary due to the utility services already exist, unless otherwise shown.

REVIEWED BY SHAWNEE COUNTY SURVEYOR, THIS _____ DAY OF _____, 2024 for compliance with KSA Chapter 56 Article 20.

Deborah J. Thomas, County Surveyor, LS #1461

ENTERED ON THE TRANSFER RECORD OF SHAWNEE COUNTY, KANSAS, THIS _____ DAY OF _____, 2024.

Cynthia A. Beck, County Clerk

FILED FOR RECORD IN THE OFFICE OF THE SHAWNEE COUNTY REGISTER OF DEEDS THIS _____ DAY OF _____, 2024, AT _____ O'CLOCK _____ M.

Rebecca J. Nioce, Register of Deeds

APPROVED BY THE TOPEKA PLANNING COMMISSION THIS _____ DAY OF _____, 2024.

Corey Dehn, Planning Commission Chairman

Dan Warner, Planning Commission Secretary

THIS SUBDIVISION HAS BEEN PRESENTED TO THE CITY COUNCIL, CITY OF TOPEKA, KANSAS, ON THE _____ DAY OF _____, 2024, FOR ACCEPTANCE OF LAND TO BE DEDICATED FOR PUBLIC PURPOSES. THE CITY COUNCIL HEREBY ACCEPTS THE LAND FOR PUBLIC PURPOSES.

By the City Council
City of Topeka, Kansas

Michael A. Padilla, Mayor

Brenda Younger, City Clerk

IN TESTIMONY WHEREOF, the owner, Southern Hills Senior Homes, LP, a Kansas limited partnership, has caused these presents to be signed this _____ day of _____, 2024.

Chris Palmer, General Partner
STATE OF _____
COUNTY OF _____, KS:

Be it remembered that on this _____ day of _____, 2024, before me, the undersigned, a notary public in and for the County and State aforesaid came Chris Palmer, General Partner of Southern Hills Senior Homes, LP, a Kansas limited partnership, who is personally known to me to be the same person who executed, the within instrument of writing.

IN WITNESS WHEREOF, I have hereunto set my hand and affixed my notarial seal the day and year last written above.

Notary Public
My Commission Expires: _____

LEGAL DESCRIPTION:

A replat of Lots 1 & 3, and Tracts A & C, Block 'A', Southland Subdivision No. 2, City of Topeka, Shawnee County, Kansas.
DEDICATION: Know all men by these presents that the undersigned owners to the above described tract of land have caused the same to be subdivided into lots, blocks and public ways which shall be known as SOUTHLAND SUBDIVISION NO. 3.
NOTICE: In the event there are other owners or those holding any proprietary interest in any land contained in this subdivision who do not appear and duly acknowledge this plat prior to the time of recording in the Office of the Register of Deeds, the plat shall be null and void.
STREETS: The public ways (streets and roads) not heretofore dedicated, are hereby dedicated to the public. Temporary turn-around easements are hereby established as shown on the accompanying plat and shall be automatically vacated when streets are extended.
EASEMENTS: Easements are hereby granted to the public as follows: "Utility Easements" to allow public utility providers, contractors, and authorized agents to locate, construct and maintain facilities to provide utility service to the public. All public utilities specifically including but not limited to water, gas, sewer, stormwater, and telecommunications may place or locate their facilities over, under and along the strips marked "utility easements". A temporary construction easement of 12-feet adjacent to the side of the utility easement is dedicated for the use of the public utilities while initial construction of the public utility's facilities are in progress.

PUBLIC DRAINAGE EASEMENT: Drainage easements are hereby established as shown to provide for the unobstructed overland flow or surface water and/or the construction and maintenance of pipe, flume, ditch or any or all improvement for the drainage of said water, all as may be determined and/or approved by the director of the department of utilities. Property owners shall not place any permanent or semi-permanent obstruction in said easement. All maintenance within the permanent public drainage easement shall be the right, duty and responsibility of the property owner(s) of the property in which the easement is so located, however, if maintenance is neglected or subject to other unusual circumstances and is determined to be a hazard or threat to public safety by the director of utilities or designee, corrective maintenance may be performed by the governing jurisdiction with costs assessed to and borne upon, said property owner(s). Officials representing the department of utilities shall have the right to enter upon the easement for purposes of periodic inspection and/or corrective maintenance.
Should one or more of the Landowners be natural persons not joined by their respective spouses, it is conclusively presumed that the land conveyed is not the residence, homestead, or principal business or falls within the footprint of the principal business of such Landowners. Should one or more of the Landowners be a legal entity other than a natural person, it shall be conclusively presumed that the person signing on behalf of that entity has been duly and legally authorized to sign and there shall be no necessity for a seal or attestation.

STORMWATER MANAGEMENT EASEMENT: Stormwater Management Easements (SME) are hereby established as described to provide for the management of storm water including, but not limited to, detention, retention, storage and treatment of storm water. Landowners and their assigns and successors (Landowners) agree to install, construct, reconstruct, replace, enlarge, repair, operate and provide perpetual maintenance of pipe, flume, ditch, swale, vegetative areas or mechanical devices for storm water conveyance and/or treatment, or any improvements in the SME for the drainage and/or treatment of said storm water. No change to the grade, topography or storm water management structures and improvements in the SME shall be made without the prior written approval of the City of Topeka, Kansas Public Works Director or designee.
Landowners shall not place or permit any permanent, semi-permanent or temporary obstruction in said SME including, but not limited to, trees, shrubs, vegetation, rocks, fences, retaining walls, landscaping, structures, buildings or other obstructions that interfere with or obstruct designed water flow and/or treatment process in an engineered channel, conduit, structure or area, nor shall Landowners obstruct, prevent or otherwise hinder ingress, egress or operation of maintenance vehicles, equipment and personnel. Upon receiving written permission from the Public Works Director or designee, Landowners may construct at their own peril other limited improvements and/or landscaping within the SME which do not and will not interfere with the function of the storm water management system. Any obstructions or improvements in the SME, permitted or not permitted, may be removed by the City of Topeka, Kansas Public Works Department or its Contractor to provide for designed water flow and/or treatment process of the storm water management system. Cost of removal, damage and any repair or replacement shall be the responsibility of the Landowner.
All maintenance and repairs within the SME shall be the right, duty and responsibility of the Landowners of the property on which the SME is located. However, if designed water flow and/or treatment processes are impeded by neglected maintenance, system failure or are subject to other unusual circumstances causing a hazard or threat to public safety, as determined by the Public Works Director or designee, emergency or corrective maintenance may be performed by the Public Works Department or its Contractor with costs charged to said Landowners. Unpaid costs shall be assessed to and imposed as a lien on the land. The Public Works Director or designee, including Contractors shall have the right to enter upon the SME for purposes of periodic or special inspection and/or corrective maintenance.

STREAM BUFFER NOTE: Stream buffer easements are hereby established as shown to provide for informal green space and the natural unobstructed overland flow of surface water in existing drainage ways. Property owner(s) shall not place permanent or semi-permanent obstructions in said easement. All maintenance within the stream buffer easement (SBE) shall be the right, duty and responsibility of the property owner(s) of the property in which the easement is so located, however, if maintenance is neglected or subject to other unusual circumstances and is determined to be a hazard or threat to public safety by the applicable public works director or designee, corrective maintenance may be performed by the governing jurisdiction with costs assessed to and borne upon said property owner(s). Officials representing the applicable department of public works or utilities shall have the right to enter upon the easement for purposes of periodic inspection and/or corrective maintenance.

FLOOD PLAIN NOTE: According to "FIRM" Map Community Panel Numbers 20117C0218E and 20117C0306E effective September 29, 2011 this property is in Flood Zone X, area of minimal flood hazard.

STREAM BUFFER NOTE: Stream Buffer Easement (SBE): Stream buffer easements are hereby established as shown to enhance and protect the integrity of the stream and provide for the natural unobstructed overland flow of surface water to and in existing drainage ways. The following practices and activities are prohibited within the SBE, except with written approval by the Utilities Director or designee.

- (1) Clearing of existing vegetation; other than trimming or cutting overgrown vegetation, removing dead vegetation or replacing vegetation.
- (2) Grading, stripping, or other soil disturbing practices.
- (3) Filling or dumping.
- (4) Draining the buffer area by ditching, underdrains, or other systems.
- (5) Use, storage, or application of pesticides or other noxious chemicals.
- (6) Housing, grazing, or other maintenance of livestock.
- (7) Storage or operation of motorized vehicles, except for maintenance and emergency use.
- (8) Placement of permanent or semi-permanent obstructions in said easement.

All maintenance permitted within the SBE shall be the right, duty and responsibility of the property owner(s) of the property in which the easement is so located, however, if maintenance is neglected or subject to other unusual circumstances and is determined to be a hazard or threat to public safety by the utilities director or designee, corrective maintenance may be performed by the city with costs assessed to and borne upon said property owner(s). Officials representing the department of utilities shall have the right to enter upon the easement for purposes of periodic inspection and/or corrective maintenance.

CERTIFICATE OF SURVEYOR:

I hereby certify that the details of this plat to be correct to the best of my knowledge and belief, that all boundary corners of this subdivision of land have been monumented and that iron pins are set as shown on the attached plat this _____ day of _____, 2024.



Patrick Leo LaFontaine, P.S. 1690
SBB Engineering, LLC
101 South Kansas Avenue
Topeka, Kansas 66603
patrick.lafontaine@sbbeng.com

SBB Engineering, LLC
transportation-site development-surveying

101 South Kansas Avenue
Topeka, Kansas 66603
Ph: (785) 215-8630 / www.sbbeng.com

SBB Proj. No.:	22-167-1
Drawn by:	JEM
Checked by:	PLL
Date:	2/6/2024
Sheet No.:	1 of 1

**STAFF REPORT – ZONING CASE
TOPEKA PLANNING DEPARTMENT**

PLANNING COMMISSION DATE: Monday, February 19, 2024

APPLICATION INFORMATION:

CASE NUMBER / NAME: CU24/01 By: Don Phillippi & Candi Bryant

REQUESTED ACTION / CURRENT ZONING: A Conditional Use Permit (CUP) for operation of a “Short-Term Residential Rental, Type II” at 116 SW The Drive presently zoned R-2 Single Family Dwelling District.

A “short term rental” is a single family home or other dwelling offered for rental by transient guests and typically advertised on Airbnb, Vrbo, or other online platforms. See definition under “Proposed Use / Summary” below.

PROPERTY OWNER: Candi Bryant & Don Phillippi

CASE PLANNER: William Sharp, Planner II

PROPERTY LOCATION / PARCEL ID: 116 SW The Drive / 0972503018011000

SIZE OF PROPERTY: 0.11 acre

STAFF RECOMMENDATION: Based upon the findings and analysis, Planning Staff recommends **APPROVAL** of Conditional Use Permit CU24/01 subject to conditions stated in the staff report.

RECOMMENDED MOTION: Based on the findings and analysis in the staff report I move to recommend to the Governing Body **APPROVAL** of the Conditional Use Permit CU24/01 subject to conditions stated in the staff report below.

Photos



116 SW The Drive. View NE



116 SW The Drive. View SE

PROJECT AND SITE INFORMATION

PROPOSED USE / SUMMARY:

A short term residential rental type II is allowed by an administrative permit under the R-2 zoning of the property provided it complies with the special use requirements of section 18.225.010 (aa). A short term residential rental type II is defined by the Topeka Zoning Code as *“any non-owner-occupied dwelling which (1) contains rooms furnished for the purposes of providing lodging to transient guests; (2) is kept, used, maintained, advertised or held out to the public as a place where sleeping accommodations are available for pay or compensation by transient guests; and (3) has no more than five bedrooms furnished for the accommodation of such guests.”* “Transient Guest” is defined in the Zoning Code as “a person who occupies a short-term residential rental for not more than 28 consecutive days.”

The applicant had been approved to operate a short term rental type II at this location from April 14, 2021 to April 14, 2023. After the applicant’s approval for a short term rental expired on April 14, 2023, the Planning Division received an application for a short term rental type II at 1829 SW 2nd St and approved that application as it met all of the standards in section 18.225.010 (aa). The applicant inquired about renewing a permit for the short term rental. Planning staff responded that because it did not meet the requirement in section 18.225.010(aa) that it be no closer than 500 feet from another short term rental type II, a permit could not be granted. As provided by section 18.225.010 (aa), an application that does not meet the standards of that section may apply for a conditional use permit (CUP).

The applicant proposes to operate a short term rental in the same manner as was approved, and as operated previously, under the administrative permit issued April 14, 2021. The CUP application includes the attached

Statement of Operations describing the operating characteristics of the use.

DEVELOPMENT / CASE HISTORY:

Located within the Greater Auburndale neighborhood and constructed in the Edgewood Park subdivision. Subject property has remained in a residential district throughout its history.

ZONING AND CHARACTER OF SURROUNDING PROPERTIES:

North: "R-2" Single-Family Dwelling District / single family residence

South: "R-2" Single-Family Dwelling District / single family residence

East: "R-2" Single-Family Dwelling District / single family residence

West: "R-2" Single-Family Dwelling District / ornamental park

COMPLIANCE WITH DEVELOPMENT STANDARDS AND GUIDELINES

BUILDING HEIGHT, SETBACKS & FENCES:

No new structures or additions are proposed for the property. The existing house was built in 1916 and the detached garage was built in 1940, so it is possible that existing buildings do not meet current setback requirements.

Building Setbacks: The "R-2" zoning district require building setbacks of:

Front 25 ft

Side 5 ft

Rear 25 ft

Height: The "R-2" zoning district has a building height limit of 42 ft.

PARKING AND ACCESS:

As required for single- and two-family dwellings.

Up to 2 on-street parking spaces may substitute for required off-street parking if the property contains frontage of 22 feet or more, exclusive of driveway approaches, sidewalk ramps, and no parking zones. A minimum of 22 feet of frontage on a street is required for each on-street parking space. TMC18.240.030

Subject property has one (1) on-street parking space on its frontage and one (1) off-street parking space. This fulfills the parking requirements for Type II non-owner occupied STRs.

LANDSCAPING AND SCREENING:

No new landscaping is required under Landscape Requirements TMC18.235. Specific Use Requirements under TMC18.225 dictate that the "exterior of the dwelling and premise shall outwardly remain and appear to be a dwelling giving no appearance of a business use."

SIGNAGE:

Signage shall comply with the sign regulations applicable to residential uses. TMC 18.225

BUILDING DESIGN STANDARDS:

Building will remain a single family residence. The house is listed on both the National Register of Historic Places and the Register of Historic Kansas Places. The Secretary of the Interior's Standards for the Treatments of Historic Properties applies to the property.

TMC 18.215.030 – GUIDELINES FOR CUP EVALUATION:

The guidelines of TMC 18.215.030 address land use compatibility, site development, operating characteristics (i.e. traffic), and the comprehensive plan.

Adherence to Guidelines

Land Use Compatibility:

- The site is contained on an existing, 0.11 acre parcel in a residential subdivision. Typical building lots in this neighborhood are similar in size.
- Density (building coverage), building height and size is similar to existing development in the neighborhood.
- The building has similar setbacks to surrounding houses.
- Building coverage is similar to other existing single family houses in the area.

Site Development:

- Off-street parking requirements have been met.
- A stormwater management plan is not required as this is an existing building with no new proposed additions or structures.
- The subject property is a historically significant structure. The building was listed on the National Register of Historic Places and Register of Historic Kansas Places in 2020. The property qualifies under Criterion C of the National Register, "Property embodies the distinctive characteristics of a type, period, or method of construction or represents the work of a master, or possesses high artistic values, or represents a significant and distinguishable entity whose components lack individual distinction." Any new change of use, or alteration to the property requires historic review by the Topeka Landmarks Commission.

Operating Characteristics: (TMC 18.225 Specific Use Requirements)

- Parking is provided to transient guests.
- External traffic arriving and exiting the property will be similar to traffic for a single-family residence. The maximum occupancy for the STR is two bedrooms.

- The STR property will adhere to special use requirements in TMC18.225.010 regarding external effects. Specifically:
 - (i) The primary entrance to all rooms accessible to guests shall be within the dwelling. An original secondary exterior entrance opening onto a porch or balcony or from a basement unit is allowed.
 - (ii) The exterior of the dwelling and premises shall outwardly remain and appear to be a dwelling giving no appearance of a business use.
 - (iii) Individual guestrooms shall not contain cooking facilities.
 - (iv) The short-term residential rental, type II shall not be used for weddings, receptions, large parties or gatherings, business meetings, or similar activities.
 - (v) Signage shall comply with the sign regulations applicable to residential uses.
 - (vi) Only retail sales of a nature clearly incidental and subordinate to the primary use of the premises as a short-term residential rental shall be permitted.
 - (vii) Parking shall comply with the parking requirements of Chapter 18.240 TMC.
 - (viii) Parking of commercial vehicles by transient guests is not permitted.
 - (xi) The trash and recycling receptacles shall be of sufficient size and number to accommodate all refuse generated by the guests.
 - (xii) Outdoor activities shall not produce any excessive, unnecessary, unusual or loud noises which: (A) create a nuisance; or (B) interfere with the use or enjoyment of property of any person of reasonable sensibilities.

PUBLIC FACILITES

TRANSPORTATION AND ACCESS:

No issues identified.

OTHER FACTORS

SUBDIVISION PLAT:

The subject property is platted in the Edgewood Subdivision.

FLOOD HAZARDS, STREAM BUFFERS:

N/A

HISTORIC PROPERTIES:

The subject property is listed in both the National Register of Historic Places / Register of Historic Kansas Places.

NEIGHBORHOOD INFORMATION MEETING:

The applicant held a neighborhood information meeting on February 1, 2024 at 116 SW The Drive. Meeting was attended by seven people, Councilwoman Karen Hiller, and Neighborhood Improvement Association President ShaMecha King Simms. No one in attendance expressed opposition to the proposed use. (meeting summary attached)

REVIEW COMMENTS BY CITY DEPARTMENTS AND EXTERNAL AGENCIES

PUBLIC WORKS/ TRAFFIC ENGINEERING:

No issues identified.

FIRE:

No issues identified.

DEVELOPMENT SERVICES:

No issues identified.

KEY DATES

APPLICATION SUBMITTAL:

January 24, 2024

NEIGHBORHOOD INFORMATION MEETING:

February 1, 2024

LEGAL NOTICE PUBLICATION:

January 24, 2024

PROPERTY OWNER NOTICES MAILED:

January 26, 2024

STAFF ANALYSIS

EVALUATION CRITERIA: In considering an application for a Conditional Use Permit, the Planning Commission and Governing Body make findings and conclusions with respect to the following pursuant to Topeka Municipal Code Section 18.245.020 in order to protect the integrity and character of the zoning district in which the proposed use is located and to minimize adverse effects on surrounding properties and neighborhood. In addition, all Conditional Use Permit applications are evaluated in accordance with the standards established in the Section 18.215.030 as related to land use compatibility, site development, operating characteristics, and consistency with the Comprehensive Plan.

- 1. The conformance of the proposed use to the Comprehensive Plan and other adopted planning policies:**
The subject property lies within an area designated "*Residential – Low Density*" by the future land map in the Land Use & Growth Management Plan - 2040. The plan establishes goals and guiding principles that protect

single-family land uses. Special use requirements in TMC 18.225.010 will be followed dictating that the property will maintain the appearance of a single-family residence. Other specific use requirements prohibit the property from acting in any other commercial activity such as retail sales and using the home as an event facility. The R-2 Single-Family Dwelling District zoning will be maintained. Approval of a short term rental will not prevent the current or future property owner from using the house primarily as a single family residence.

2. **The character of the neighborhood including but not limited to: land use, zoning, density, architectural style, building materials, height, structural mass, siting, open space and floor-to area ratio:** The operation of a short term rental will have no effect on the physical character of the neighborhood. The short term rental will be required to operate in accordance with standards for short term residential rentals, type II, which will help to ensure the property retains the appearance and other characteristics of a single family residence. 116 SW The Drive was listed on the State and National Register of Historic Places in 2020. The property qualifies under National Register Criteria C, "Property embodies the distinctive characteristics of a type, period, or method of construction..." The neighborhood has historically remained a suburban neighborhood throughout its existence. The layout of the house comes from a Garlinghouse approved plan and the structure retains excellent integrity as a craftsman/bungalow dwelling. The streets in the neighborhood are laid out in grid pattern with the exception of "The Drive". This local street starts at the intersection of NW Story St & SW 1st St then curves northeast before turning southeast terminating on SW 2nd St. The 3.6 acres in size Edgewood Park sits west of the subject property.
3. **The zoning and uses of nearby properties, and the extent to which the proposed use would be in harmony with such zoning and uses:** The property is zoned "R-2" Single Family Dwelling District as are all adjacent parcels. Approval of the requested conditional use permit will not result in a change in the zoning map. The applicant's short term rental (STR) had already been operating for the past two years at this location with an approved certificate to operate before it expired. At that time it followed all of the special use requirements for a short term residential rental type II. During that period, no complaints were received regarding the subject property's STR operation. Under the conditional use permit, it will follow all of the same requirements with the exception of it being closer than 500 feet from another short term residential rental type II.
4. **The suitability of the property for the uses to which it has been restricted under the applicable zoning district regulations:** The subject property has remained in the "R-2" Single-Family Dwelling District or another similar residential zoning district since the creation of the subdivision. The property is suitable for the uses to which it is restricted under its R-2 zoning. The use of the property as a single-family dwelling can still continue if the short term rental ceases operation.
5. **The length of time the property has remained vacant as zoned:** The property is not vacant. The property has remained a single-family dwelling since its construction in the early twentieth century and the dwelling has been occupied for the majority of its history.
6. **The extent to which the approval of the application would detrimentally affect nearby properties:** Based upon the surrounding land uses, approval of this application is not anticipated to have a detrimental effect upon nearby properties, as approved under the CUP. The only special use requirement being waived for the CUP is the 500 feet buffer for other type II non-owner occupied short term rentals. This regulation was added to the short term rental ordinance to prevent clustering of type II's within a neighborhood block. Specifically, the average length of a neighborhood block is approximately 500 feet. The other type II short term rental, which has been approved by administrative permit, is approximately 260 feet away from the subject property. However, that short term rental is on SW 2nd Street, and not on The Drive. 116 SW The Drive has already been used as a short term rental residence for over two years in the neighborhood with the City receiving no complaints.
7. **The extent to which the proposed use would substantially harm the value of nearby properties:** The proposed use will not likely have a negative impact upon the value of nearby properties. 116 SW The Drive

was chosen to be nominated to the State and National Register of Historic Places due to the applicant's dedication to maintaining and rehabilitating the property under historic preservation guidelines ensuring that they meet the Secretary of Interiors Standards for Rehabilitation. The structure has retained excellent integrity because of the owner's efforts. The applicant, along with the Topeka Landmarks Commission, conducted a historic preservation workshop in 2019 at 116 SW The Drive. The event was a success with volunteers and historic preservation enthusiasts.

8. **The extent to which the proposed use would adversely affect the capacity or safety of the portion of the road network influenced by the use, or present parking problems in the vicinity of the property:** The proposed use is not likely to have an adverse impact upon the road network based on the application and descriptions of the proposed CUP. The property is served by streets classified as "local" roads with the capacity to handle the traffic generated by the use. The applicant has sufficient off-street parking with some available on-street parking. For type II non-owner occupied STRs the requirement is the same as a regular single-family dwelling. The applicant has one on-street space with frontage along the house of 40 feet. The property also has one off-street space in the alley with a detached garage. These conditions meet the requirements for parking in the short term specific use standards in Title 18.
9. **The extent to which the proposed use would create excessive air pollution, water pollution, noise pollution or other environmental harm:** Quiet hours will be maintained from 10:00 pm to 7:00 am as stated on the statement of operations provided by the applicant. No other commercial business is allowed to operate on the premises besides the operation of a short term rental residence. Compliance with the applicable standards for short term rentals will help to ensure the use will have no more negative environmental effects than would be generated by a single family residence.
10. **The economic impact of the proposed use on the community:** The short term rental operation at 116 SW The Drive brings in visitors and guests to Topeka with an average stay of five days. It has been said by many that the income generated by a short term rental enables the owner to maintain the property in good condition.
11. **The gain, if any, to the public health, safety and welfare due to denial of the application as compared to the hardship imposed upon the landowner, if any, as a result of denial of the application:** There is no apparent gain to the public health, safety and welfare by denial of the application since approval of the application will be a continuance of the short term rental operation that was ongoing at this location for two years. Granting the conditional use permit will let the applicant continue on with operating a short term rental like they have done previously.

STAFF RECOMMENDATION:

RECOMMENDATION: Based upon the above findings and analysis, Planning staff recommends **APPROVAL** subject to conditions of approval.

RECOMMENDED MOTION: Based on the findings and analysis in the staff report I move to recommend to the Governing Body **APPROVAL** of the Conditional Use Permit CU24/01 subject to the following conditions of approval:

1. Use and development of the site in accordance with the approved Conditional Use Permit (CU24/01) and Statement of Operations from applicant dated February 8, 2024 or as revised by these conditions.
2. In the event of substantial changes in operations, the applicant shall submit a revised Statement of Operations to the Planning Department to allow staff to ascertain compliance with the Conditional Use Permit.

3. The Conditional Use Permit for the short term residential rental, type II shall expire after a period of 24 months from the date of its approval by the Topeka Governing Body. If, upon a written request made by the owner within six months from date of the expiration of the conditional use permit, and after finding that the short term rental has and will continue to comply with all special use requirements for a short term residential rental type II with exception of standard (aa)(1)(ix) regarding its distance from any other short term rental type II, the Planning Director may approve one extension of the conditional use permit not to exceed an additional 24 months.

Attachments / Exhibits:

1. Aerial Map
2. Zoning Map
3. Future Land Use Map
4. Applicant's Statement of Operations
5. Applicant's Neighborhood Meeting Summary
6. Kansas Historic Resources Inventory 116 SW The Drive



Topeka Planning Division

 Subject Property

Aerial Map



Topeka Planning Division

 Subject Property

Zoning Map

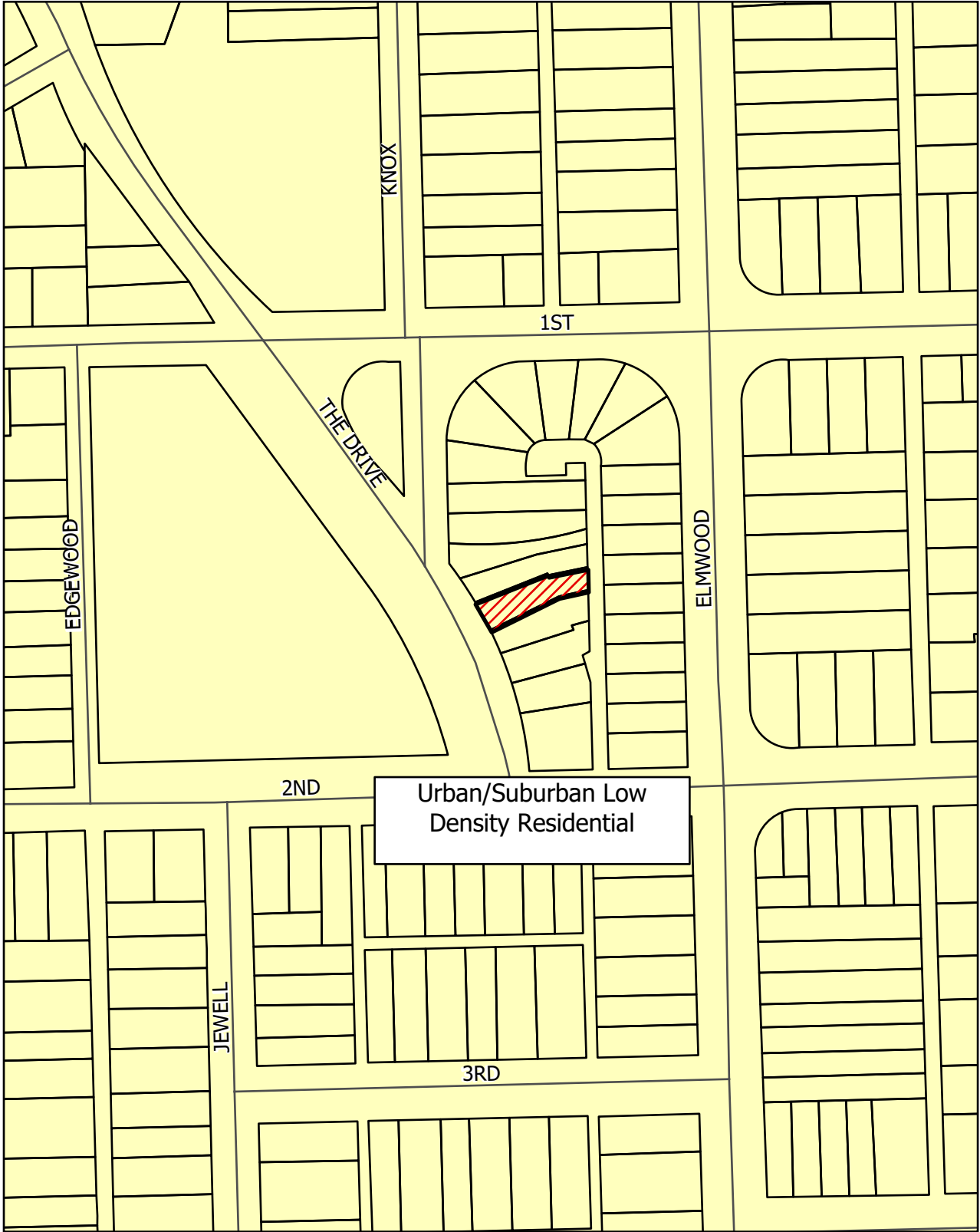

Topeka Planning Division

 Subject Property

Future Land Use Map

2/8/2024

Statement of Operations.

The Historic Landmark at 116 SW The Drive has been a Short-Term Rental (STR) over the last 2 years. Dubbed the “She Shed” the 1904 bungalow offers space for up to 6 guests with 2 Bedrooms and 2 Baths. The She Shed has an occupancy rate of about 50 percent (16 nights a month), with minimum 2-night stays with an average stay of about 5 days. Longer stays are around 7 days. On-site parking includes 2 parking spaces (one-car garage & one surface parking space off the rear alley), with an off-site parking space in the front of the property on the street. Trash pickup is accomplished with trash bins located on the alley (trash service and recycling is provided by Shawnee County Trash). Parties are not allowed and Quiet Time is from 10:00pm to 7:00am. Pets are allowed to stay with guests, but are not allowed to be left in the backyard alone.

The Property is well appointed on the exterior (and interior) and includes routine landscape service for grass mowing and leaf removal and is always well kept. As an example, last year the grass on the north part of the front lawn was replaced with new sod in an effort to control the weeds that come from adjacent properties. With a high-level of maintenance and care, the property is one of the best showing properties in the neighborhood. To show the owner’s positive commitment to the City of Topeka, the owners of the She Shed also own the STR at 1200 SW Taylor Street that was used as part of a presentation to the Planning Commission to show what is good about Holliday Park.



CITY OF TOPEKA

Planning Division
Holliday Building, 620 SE Madison St., Unit 11
Topeka, KS 66607

Dan Warner, AICP, Director
Tel: 785-368-3728
www.topeka.org

MEMORANDUM

To: File
From: William Sharp, Planner II
Date: February 1, 2024
RE: Neighborhood Information Meeting, CU24/01

On February 1, 2024 at 5:30 pm a neighborhood information meeting was conducted at 116 SW The Drive, regarding the conditional use permit (CUP) application for the property.

The applicants, Don Phillippi and Candi Bryant attended the meeting. William Sharp and Dan Warner attended the meeting on behalf of City of Topeka. Seven people attended the meeting along with Councilwoman Karen Hiller and Old Town NIA President ShaMecha King Simms. Guests in attendance raised questions regarding the CUP process and if they were able to provide public comment at the upcoming Planning Commission meeting. The meeting concluded at 6:15 pm.

Kansas Historic Resources Inventory

Printed: 02/05/2024



177-4185
Smith, Arthur, House
116 SW THE DRIVE
Topeka

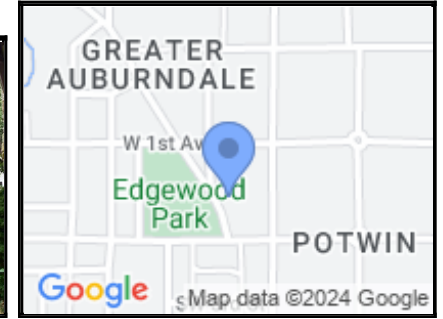

LOCATION:

County: Shawnee

Address: 116 SW THE DRIVE

Address Remarks:

City: Topeka

Zip: 66606

Parcel ID: 097-25-0-30-18-011.00-0

Legal Description:

Legal Description Remarks: EDGEWOOD, S 2 1/2 LT 24 & TR BEG AT NE COR LT 25, TH ELY 57 1/2 FT, TH S 28.9 FT, TH W 40 FT, TH N 30 FT TO POB & ALL LOT 25

Latitude, Longitude 1: 39.062515 -95.697685

Latitude, Longitude 2:

Latitude, Longitude 3:

Latitude, Longitude 4:

Datum: WGS84

DESCRIPTION:

Historic Name: Smith, Arthur, House

Alternate Name:

Historic Function: Domestic

Subcategory: Single Dwelling

Historic Function Remarks: 1) 1926 City Directory: A.R. Smith. 2) 1930 Federal Census: Arthur R. Smith (bookkeeper, bank), Claribel C. Smith.

Present Function: Domestic

Subcategory: Single Dwelling

Present Function Remarks:

Residential/Commercial/Religious Style: Craftsman/Bungalow

Secondary Style:

Barn Type: Not Applicable

Bridge Type: Not Applicable

Landscape Type: Not Applicable

Physical Description/Remarks: October 2019: the vinyl siding has been removed from the house exposing the clapboard wood and shingles in the upper portion of the elevations.
May 2019: Garlinghouse Plan 222, Bungalow Homes. This one-and-a-half-story Craftsman bungalow faces west and has a cobblestone foundation and a front-gabled roof with asphalt shingles. The exterior is clad with vinyl siding. A front-gabled dormer rises from the north and south slopes of the roof. A full-width recessed porch spans the west (primary) elevation. The porch is accessed via a set of wood steps with a wood handrail. The porch has knee walls clad with vinyl siding and grouped slender square columns. The west elevation has three bays. The outer bays each contain a one-over-one double-hung wood window. The central bay contains a historic entrance door with glazing and an aluminum storm door. The upper half-story contains a seven-light fixed wood window.

Plan Form: Rectangle

Commercial Building Type: Not Applicable

Roof Form: Gable-Front

Stories: 1 1/2

Condition: Good

Principal Material: Wood

Condition Remarks: The vinyl siding was removed in May 2019 exposing the historic wood siding.

Architect/Designer/Builder: Garlinghouse

Year of Construction: 1916

Certainty: Estimated

Date Notes: Garlinghouse Bungalow Homes publication

General Remarks:

Ancillary Structures: Garage/Carriage House

Ancillary Structure Remarks: This one-story, one-car garage faces east onto an alley. It has wood plank siding and a front-gabled roof with asphalt shingles. The east elevation contains a wood paneled overhead door with glazing for vehicle access.

REGISTER STATUS:

Listed in State Register: Yes

Date of State Listing: 08/01/2020

Listed in National Register: Yes

Date of National Listing: 10/05/2020

Historic District:

Demolished:

Date Demolished (if applicable):

Potentially Eligible for National Register:

Register Status Remarks: Fall 2019, the vinyl siding was removed from the home and it is now considered eligible for NR under C for Garlinghouse MPDF.
May 2019: Non-historic siding compromises the integrity of the resource. The garage was built circa 1940 according to the Shawnee County tax assessor; it may contribute to a potential historic district if it dates to the period of significance.

Thematic Nomination (MPDF): Historic Houses of the Garlinghouse Company in Topeka

National Historic Landmark:

SURVEY INFORMATION:

Survey 1

Survey Project Name: Topeka - Auburndale Area 1 (HPF 2017)

Sequence Number: 219

Surveyed By: BARNHART, RACHEL

Survey Date: 01/20/2017

Survey 2

Survey Project Name: Topeka - Garlinghouse Survey (HPF 2018)

Sequence Number: 123

Surveyed By: Lenhausen, Emily

Survey Date: 01/09/2019

IMAGES & DOCUMENTS



116 SW The Drive. Topeka, Shawnee County, Kansas. View SE. Brad Finch. 12-21-16.



116 SW The Drive. Topeka, Shawnee County, Kansas. View NE. Brad Finch. 12-21-16.



116 SW The Drive. Topeka, Shawnee County, Kansas. Garage. View NW. Brad Finch. 12-21-16.



116 SW The Drive. Topeka, Shawnee County, Kansas. Site plan. 12-21-16.



116 SW The Drive. Topeka, Shawnee County, Kansas. View SE. 01/09/2019. Finch, Brad.



116 SW The Drive. Topeka, Shawnee County, Kansas. View NE. 01/09/2019. Finch, Brad.



116 SW The Drive. Topeka, Shawnee County, Kansas. Site Map.



116 SW The Drive. Topeka, Shawnee County, Kansas. Rosin Preservation. August 2019



116 SW The Drive. Topeka, Shawnee County, Kansas. Rosin Preservation. August 2019



116 SW The Drive. Topeka, Shawnee County, Kansas. Rosin Preservation. August 2019



116 SW The Drive. Topeka, Shawnee County, Kansas. Rosin Preservation. August 2019



116 SW The Drive. Topeka, Shawnee County, Kansas. Rosin Preservation. August 2019



116 SW The Drive. Topeka, Shawnee County, Kansas. Rosin Preservation. August 2019



116 SW The Drive. Topeka, Shawnee County, Kansas. Rosin Preservation. August 2019



116 SW The Drive. Topeka, Shawnee County, Kansas. Rosin Preservation. August 2019



116 SW The Drive. Topeka, Shawnee County, Kansas. Rosin Preservation. August 2019

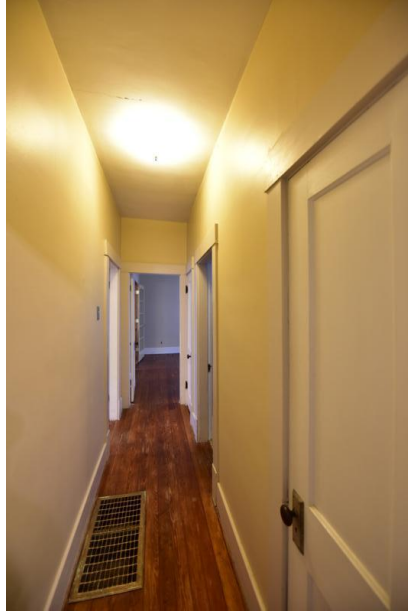

116 SW The Drive. Topeka, Shawnee County, Kansas. Rosin Preservation. August 2019



116 SW The Drive. Topeka, Shawnee County, Kansas. Rosin Preservation. August 2019



116 SW The Drive. Topeka, Shawnee County, Kansas. Rosin Preservation. August 2019



116 SW The Drive. Topeka, Shawnee County, Kansas. Rosin Preservation. August 2019

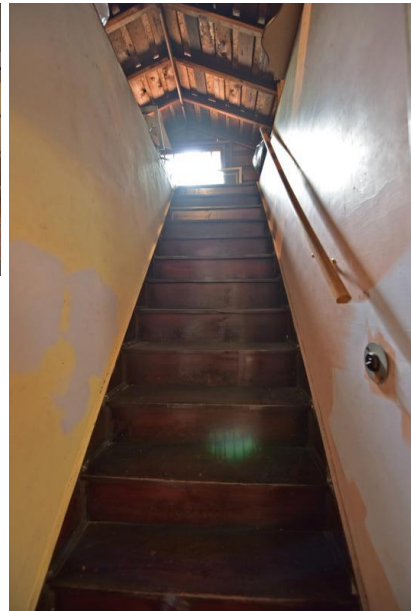

116 SW The Drive. Topeka, Shawnee County, Kansas. Rosin Preservation. August 2019



116 SW The Drive. Topeka, Shawnee
County, Kansas. Rosin Preservation.
August 2019



116 SW The Drive. Topeka, Shawnee
County, Kansas. Rosin Preservation.
August 2019



National Register
Nomination. 2020.